

# CTYPO493F787

1987 Catalina 34, Hull # 493

November 2024; Rev K

(AC wires not shown)

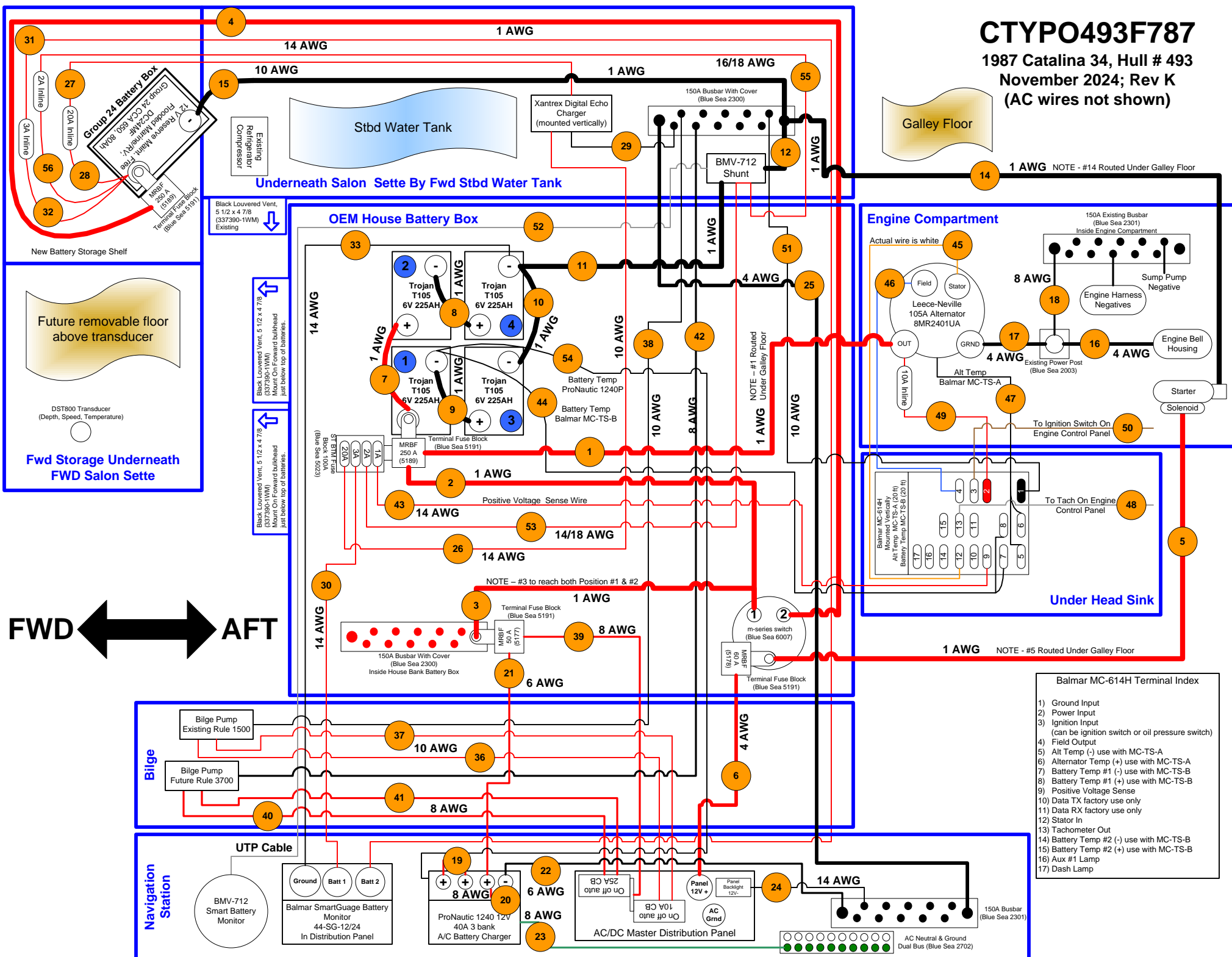

FWD ← → AFT

- Balmar MC-614H Terminal Index**
- 1) Ground Input
  - 2) Power Input
  - 3) Ignition Input (can be ignition switch or oil pressure switch)
  - 4) Field Output
  - 5) Alt Temp (-) use with MC-TS-A
  - 6) Alternator Temp (+) use with MC-TS-A
  - 7) Battery Temp #1 (-) use with MC-TS-B
  - 8) Battery Temp #1 (+) use with MC-TS-B
  - 9) Positive Voltage Sense
  - 10) Data TX factory use only
  - 11) Data RX factory use only
  - 12) Stator In
  - 13) Tachometer Out
  - 14) Battery Temp #2 (-) use with MC-TS-B
  - 15) Battery Temp #2 (+) use with MC-TS-B
  - 16) Aux #1 Lamp
  - 17) Dash Lamp

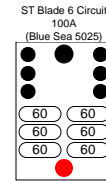
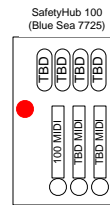
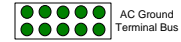
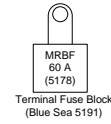
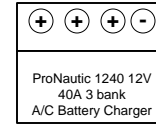
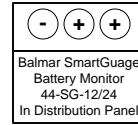
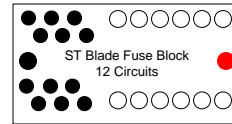
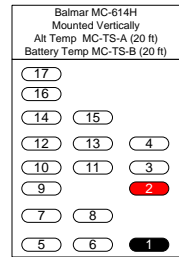
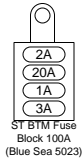
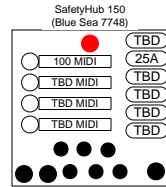
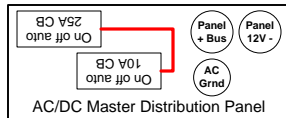
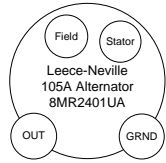
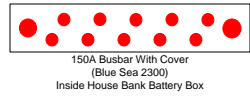
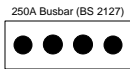
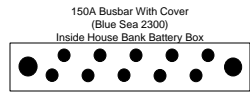

Black Louvered Vent, 5 1/2 x 4 7/8  
(337390-1WM)  
Mount On Forward bulkhead  
just below top of batteries.