

Seaward *Products*

WATER HEATERS

OWNER'S MANUAL

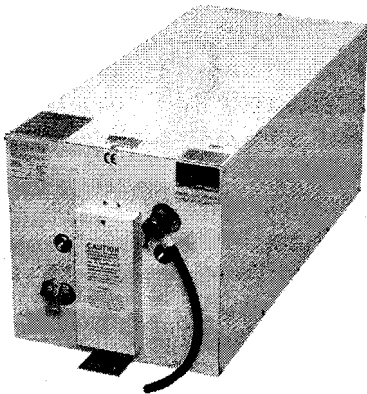

H2850EW-3000, H2850ES-3000
H2850EW-4500, H2850ES-4500

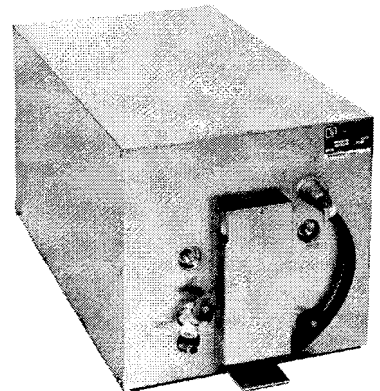

H2000, H2050, H2200, H2250
HF2000, HF2050, HF2200, HF2250

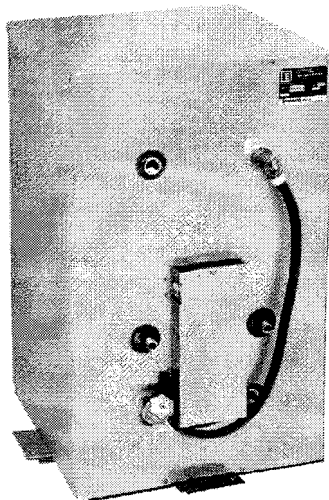

S1800, S1850, S1900, S1950

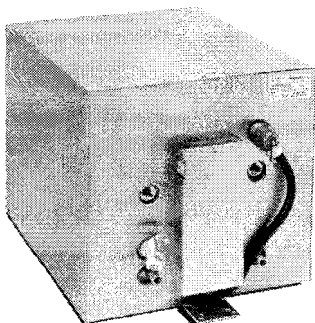

S600, S700, F600, F700
S650, S750, F650, F750

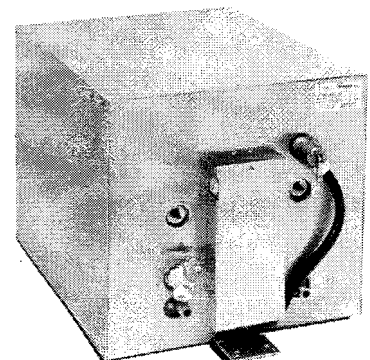

S1100, S1200, F1100, F1200
S1150, S1250, F1150, F1250

Serial Number: _____

830460 - F08

IMPORTANT SAFETY INSTRUCTIONS

WARNING

When using electrical appliances, basic safety precautions to reduce the risk of fire, electrical shock, or injury to persons should be followed, including:

1. READ ALL INSTRUCTIONS BEFORE USING THIS WATER HEATER.
2. This water heater must be grounded. Connect only to properly grounded source. See "GROUNDING INSTRUCTIONS" found on Page 4, Item 7.
3. Install or locate this water heater only in accordance with the provided installation instructions.
4. Use this water heater only for its intended use as described in this manual.
5. Do not use an extension cord set with this water heater. If no junction box is available adjacent to the water heater, contact a qualified electrician to have one properly installed.
6. As with any appliance, close supervision is necessary when used by children.
7. Do not operate this water heater if it has a damaged power supply line, if it is not working properly, or if it has been damaged or dropped.
8. This water heater should be serviced only by qualified service personnel. Contact nearest authorized service facility for examination, repair, or adjustment.

WARNING

This water heater is equipped with a heat exchanger. Extended engine coolant circulation through the heater may result in excessively hot water.

This water heater tank and heat exchanger is made of aluminum. Some engine manufacturers recommend that cooling system be flushed periodically. Caustic chemicals are commonly used. **DO NOT** flush caustic chemicals (such as Nalcool) through your system with the heat exchanger hooked up or damage **WILL** occur to heater.

If flushing is required by your engine manufacturer, you must isolate heater from this process. After system flushing is complete and neutralized, you can then re-plumb heater. Make sure recommended automotive type premixed ethylene glycol coolants such as Prestone, Xerex, or Peak are used for replacement. Damage that occurs to heater due to chemical reaction by caustic chemicals **IS NOT** under warranty.

CAUTION

Hydrogen gas can be produced in a hot water system served by these heaters that have not been used for a long period of time (generally 2 weeks or more.) Hydrogen gas is extremely flammable. To reduce the risk of injury under these conditions, it is recommended that the hot water faucet be opened for several minutes at the kitchen sink before using any electrical appliance connected to the hot water system. If hydrogen is present, there will be an unusual sound such as air escaping through the pipe as the water begins to flow. There should be no smoking or open flame near the faucet at the time it is open.

Small amounts of electric currents may move to your boat through your shore cord, causing galvanic damage to your water heater. To help prevent possible damage, a galvanic isolator is recommended. Galvanic corrosion **IS NOT** covered under warranty.

ANODES

In a small number of instances tap water may have sufficient concentrations of dissolved salts to cause corrosion of the heater tank. Anode rods preserve the life of a water heater by corroding themselves so the water heater doesn't. These anode rods are easy to install! Simply replace the drain plug with this product to protect the water heater tank. If you live in an area known to have such water please contact our customer service department at 562-699-7997 to order a magnesium anode.

Note: DO NOT USE ZINC ANODES

Part No. 74556, Magnesium 4" Anode with $\frac{3}{4}$ " thread to replace drain valve.
Cost = \$20.00 including freight.

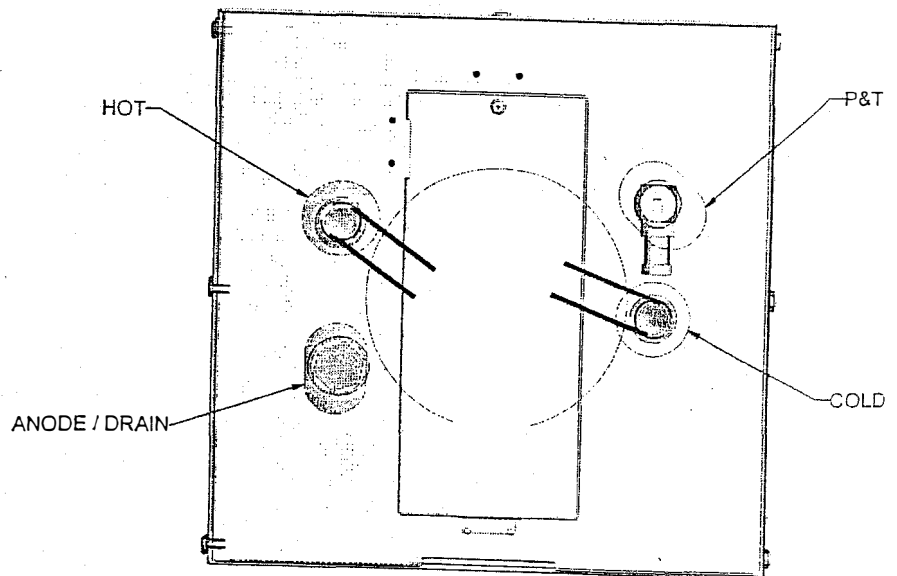
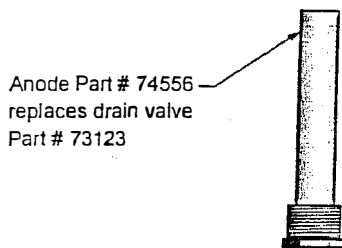

NOTICE

This temperature / pressure valve may weep during initial operation. This is normal. The valve will seat itself with use. A drain hose should be installed at this valve directed into bilge.

If the boat is connected to the dockside water system, make sure to turn off the system at the dock when not attended. Also make sure a pressure regulator is used to control pressure.

OPERATING INSTRUCTIONS

1. Fill water system and completely fill tank.
2. Locate and turn remote electrical switch to "ON".
3. Turn switch to "OFF" position prior to draining water system.
4. The temperature / pressure valve may weep during initial operation. This is normal. The valve will seat itself with use.

NOTE: DO NOT OPERATE HEATER WITHOUT ELEMENT BEING SUBMERGED IN WATER.

MAINTENANCE

1. Check heat exchanger lines for leaks at regular intervals. A leak in the system will cause coolant loss and may damage engine.
2. Flush tank periodically to help prevent build-up of deposits.
3. Protect against damage from freezing temperatures (32° F or less)

Please review the following:

- a) Drain tank by fully opening drain valve. Open T&P valve to help relieve vacuum in tank. (See item 2 in exploded view)
- b) It is recommended you winterize your fresh water system. First complete step 3a, then follow instructions of your local supplier regarding chemicals to use and how to use them.

CAUTION

If heater has been run without water and now fails to work, fill heater tank with water and push electric reset button high limit switch under wire access cover before calling for service.

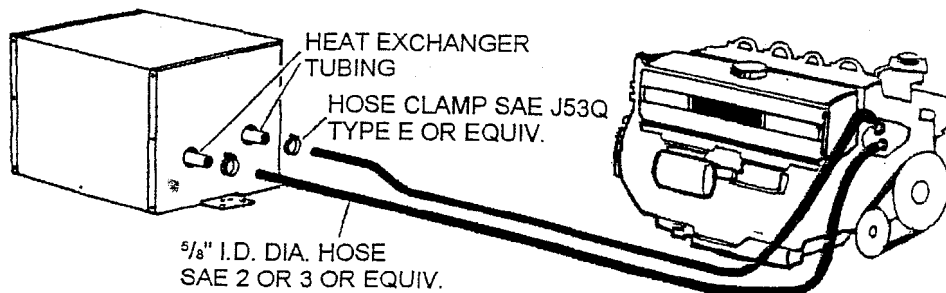

NOTE: Whether heat exchanger tubes are out the Front or Rear the same connection information applies.

Figure 1

INSTALLATION

NOTE: DO NOT INSTALL THE WATER HEATER ON IT'S SIDE OR UP SIDE DOWN.

1. Locate water heater at engine level as close to engine as possible.
2. Secure mounting brackets to structure with eight #12 minimum screws or ¼ - 20 minimum cap screws and nuts.
3. Connect cold water supply and hot water outlet to heater as marked, ½" N.P.T. fittings.
4. Connect heat exchanger system described in **Figure 1**. Make sure coolant system is completely purged of air and full of coolant before operating.
5. Pressure temperature relief valve is factory installed. The pressure relief shall limit the pressure to 127.5 PSI (879.3 KPA) minimum, 150 PSI (1034.2 KPA) maximum.

The valve must be oriented, provided with tubing, or otherwise installed so that discharge can exit no more than 6 inches above, or at any distance below the structural floor, and cannot contact any live electrical part.

Install replacement temperature and pressure protective equipment required by local codes, but not less than a combination temperature and pressure relief valve certified as meeting the requirements for relief valves and automatic gas shutoff devices for hot water supply systems, ANSI Z21.22 by a nationally recognized testing laboratory that maintains periodic inspection of production of listed equipment or materials.

6. Connect the electrical supply by a qualified electrician. The electrical supply shall be permanent wiring, armored cable or conduit, per national electrical code NFPA 70, with a minimum capacity of 1500 watts.

On 120 volt circuits, use a UL approved 15 amp circuit breaker. On 240 volt circuits, use a 10 amp approved circuit breaker per leg.

7. **GROUNDING INSTRUCTIONS:** The supply ground shall be connected to the green wire located in the water heater wiring compartment. Do not place switch in the grounding circuit.
8. **RESET INSTRUCTIONS:** The heater is equipped with a high limit switch which can be manually reset. If the limit switch activates, proceed as follows:
 - Turn power off at main power panel or remote switch
 - Remove wiring access cover
 - Depress red button on high temperature limit switch
 - Replace cover and turn power on
 - If temperature limit switch reactivates, contact a Seaward Products authorized service center.

WIRING DIAGRAM FOR 120V

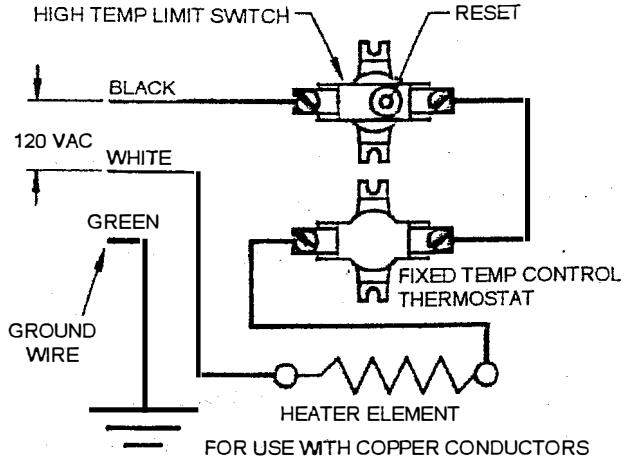

CAUTION: TO REDUCE RISK OF SHOCK OR FIRE, USE ONLY ON A UTILITY SYSTEM HAVING A MAXIMUM 120/250 VOLT, THREE WIRE SYSTEM.

120 VOLT AC

WIRING DIAGRAM FOR 240V

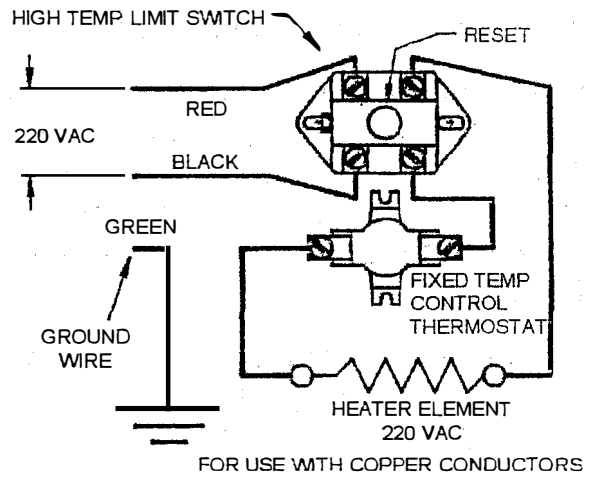

240 VOLT AC

Winterizing Your Seaward Products Water Heater

Winterizing your fresh water system is an essential procedure that will maintain the life and longevity of your Seaward Products water heater and fresh water tanks. To ensure that your fresh water system has adequate protection for winter storage, use the following recommended winterizing procedure:

Winterizing the Water Heater and Fresh Water System

1. Locate the fresh water tank drain valve or plug and allow the fresh water tanks to drain until approximately 115% to 120% of the water heater capacity remains in the tanks.

Example: If water heater is 11 gallons = 12 to 13 gallons in fresh water tanks.

2. Treat the remaining fresh water left in the fresh water tanks with "Winterizing Chemicals". Winterizing chemicals are non-toxic antifreeze that is a propylene-glycol base and are safe for potable water systems.

NOTICE

DO NOT USE THE TYPE OF ANTI-FREEZE THAT IS USED TO WINTERIZE AUTOMOBILES. THIS IS NOT SAFE FOR POTABLE WATER SYSTEMS.

NOTICE

Antifreeze can be very corrosive to the anode rod. The result will be accelerated deterioration of the rod and heavy sediment in the tank. If you intend to winterize by adding antifreeze into the system and your water heater is equipped with an anode, remove the anode rod (storing it for the winter) and replace it with a 3/4" male pipe thread drain plug.

3. Turn off 120V or 240V AC power.
4. Turn on fresh water pump.
5. Open each faucet and water outlet one at a time until winterizing chemical is apparent at the opening.
6. Turn off fresh water pump and leave all faucets and water outlets open over winter.
7. Locate the water heater drain and pressure relief valve and allow all water to drain from water heater until empty. Leave water heater drain and pressure relief valve open over winter.

CAUTION

SPECIAL PRECAUTIONS MUST BE USED WHEN DRAINING AND FILLING AN ELECTRIC WATER HEATER. ELECTRICITY MUST BE TURNED OFF BEFORE DRAINING AND REFILLING WATER HEATER TANKS.

EXPLODED VIEW

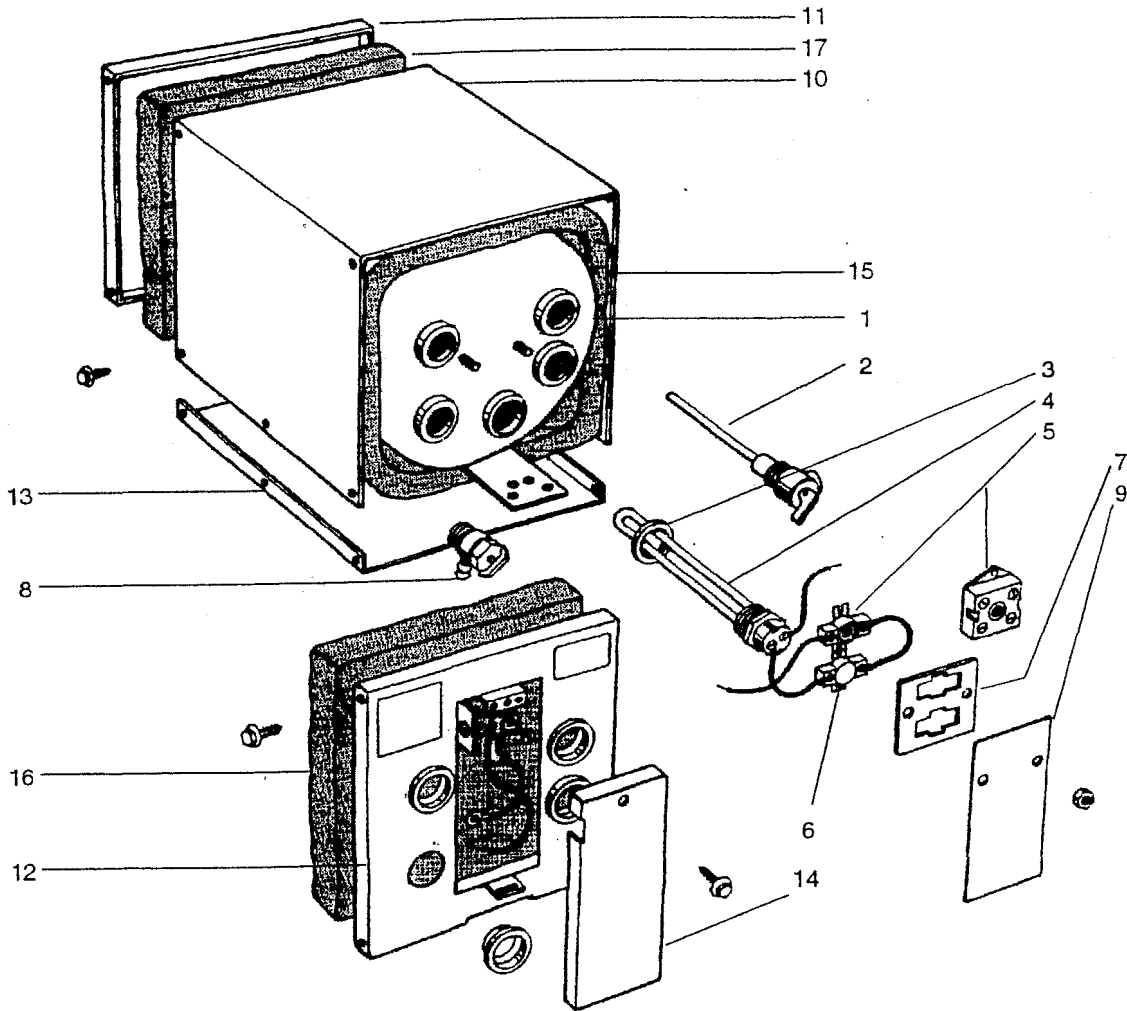

EXPLODED VIEW

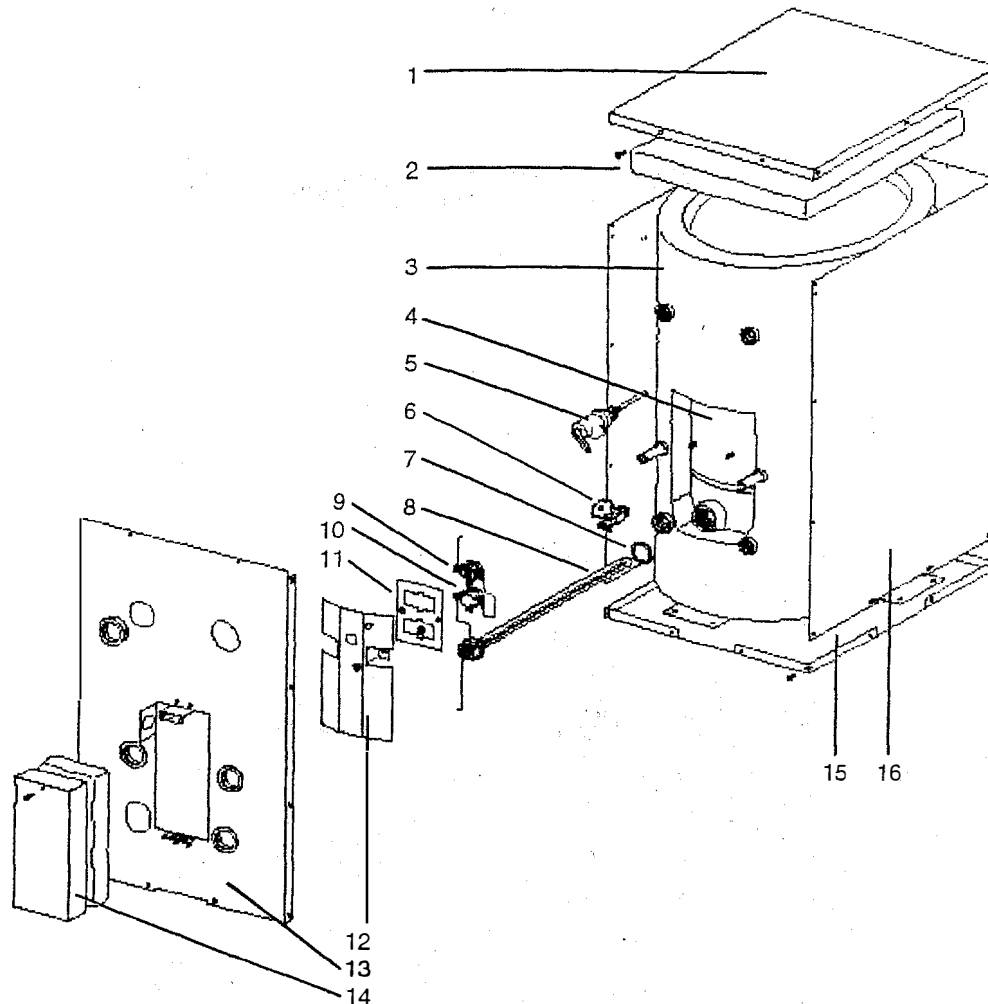

PARTS LIST MODELS S1800/S1850/S1900/S1950

ITEM	MODEL NO.	PART. NO.	DESCRIPTION	ITEM	MODEL NO.	PART. NO.	DESCRIPTION
1.	S1800/S1850	73398	Top Panel, Galvanize	11.	120 VOLT	73148	Mtg Plate, Switch
	S1900/S1950	73408	Top Panel, S.S.		240 VOLT	73171	Mtg Plate, Switch
	S1800/S1850	74689	Top Panel, White	12.	ALL MODELS	73145	Shield, Wires
2.	S1800/S1850/S1900/S1950	73404	Insulation, Top	13.	S1800/S1850	73397	Front Panel, Galv
Not Shown	S1800/S1850/S1900/S1950	73404	Insulation, Base		S1900/S1950	73407	Front Panel, S.S.
3.	S1800/S1850/S1900/S1950	73409	Insulation, Wrap		S1800/S1850	74690	Front Panel, Wte
4.	S1800/S1850/S1900/S1950	80263	Tank Assembly	14.	S1800/S1850	73141	Access Cover, Galv
5.	ALL MODELS	73127	Temp/Pressure Valve		S1900/S1950	73293	Access Cover, S.S.
6.	ALL MODELS	73123	Drain Valve		S1800/S1850	74669	Access Cover, Wte
7.	ALL MODELS	73124	Gasket, Heating Element	15.	S1800/S1850	73396	Base, Galvanize
8.	120 VOLT	74031	Heating Element		S1900/S1950	73406	Base, S.S.
	240 VOLT	74032	Heating Element		S1800/S1850	74688	Base, Wte
9.	120 VOLT	74563	High Limit Switch	16.	S1800/S1850	73395	Wrap, Galvanize
	240 VOLT	74607	High Limit Switch		S1900/S1950	73405	Wrap, S.S.
10.	ALL MODELS	73129	Thermostat		S1800/S1850	74687	Wrap, White

NOTE: FOR ALL WHITE POLY COATED MODELS ALL PARTS ARE COMMON EXCEPT WRAP. SEE PARTS LIST ABOVE FOR WHITE PARTS.

EXPLODED VIEW

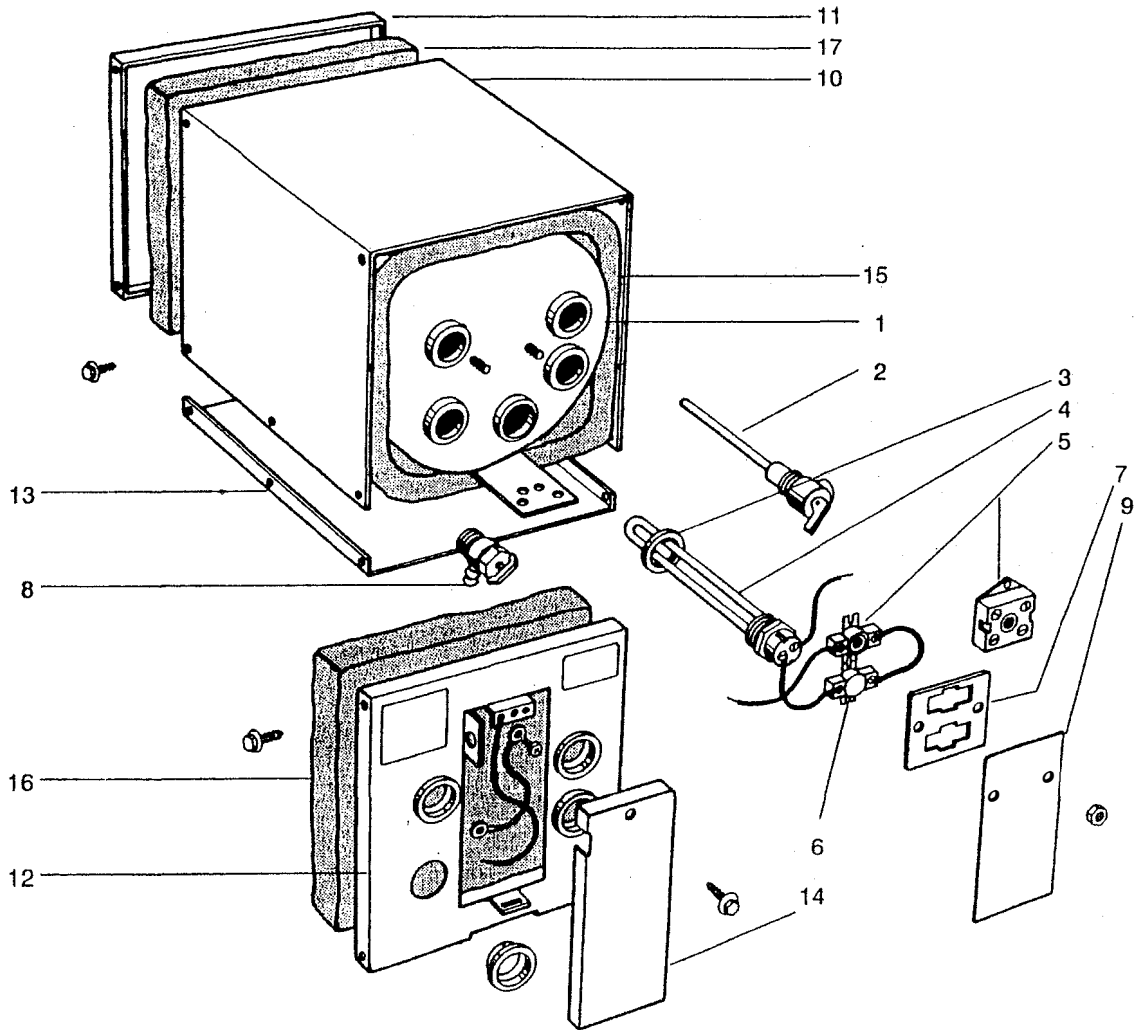

**PARTS LIST
MODELS
H2850EW-3000, H2850EW-4500
H2850ES-3000, H2850ES-4500**

ITEM	MODEL NO.	PART NO.	DESCRIPTION
1	H2850ES-3000, H2850ES-4500 H2850EW-3000, H2850EW-4500	80491 80491	TANK ASSEMBLY TANK ASSEMBLY
2	ALL	73127	TEMPERATURE/PRESSURE VALVE
3	ALL	73124	GASKET, HEATING ELEMENT
4	H2850ES-3000, H2850EW-3000 H2850ES-4500, H2850EW-4500	74715 75086	3000W HEATING ELEMENT 4500W HEATING ELEMENT
5	240V	74607	HIGH LIMIT SWITCH
6	ALL	73129	THERMOSTAT
7	ALL	73171	PLATE, THERMOSTAT MOUNTING
8	ALL	73123	DRAIN VALVE
9	ALL	73145	SHIELD, WIRES
10	H2850ES-3000, H2850ES-4500 H2850EW-3000, H2850EW-4500	75234 75055	WRAP, S.S. WRAP, WHITE
11	H2850ES-3000, H2850ES-4500 H2850EW-3000, H2850EW-4500	73290 74667	BACK PANEL, S.S. BACK PANEL, WHITE
12	H2850ES-3000, H2850ES-4500 H2850EW-3000, H2850EW-4500	73289 74666	FRONT PANEL, S.S. FRONT PANEL, WHITE
13	H2850ES-3000, H2850ES-4500 H2850EW-3000, H2850EW-4500	75235 75056	BASE, S.S. BASE, WHITE
14	H2850ES-3000, H2850ES-4500 H2850EW-3000, H2850EW-4500	73291 74669	ACCESS, COVER S.S. ACCESS, COVER WHITE
15	ALL	74616	INSULATION, WRAP
16	ALL	73176	INSULATION, FRONT
17	ALL	73331	INSULATION, BACK

NOTE: FOR ALL WHITE POLY COATED MODELS ALL PARTS ARE COMMON EXCEPT WRAP. SEE PARTS LIST ABOVE FOR WHITE PARTS.

LIMITED TWO YEAR WARRANTY

SEAWARD PRODUCTS warrants the products delivered will be:

- A. Free from (1) encumbrances and (2) defects in material and workmanship under the normal use and service.
- B. Will meet applicable specifications and descriptions at time of delivery to BUYER.

The obligation of SEAWARD under this warranty is limited to the repair, Rework, or replacement, at SEAWARD'S option, any part or component thereof, which examination discloses to our satisfaction to have been nonconforming or defective. SEAWARD, after establishing customer's purchase date and determining problem to be under warranty, will either repair the product at their factory or authorized service center and allow labor and parts for (2) two years from purchase date. Transportation charges are the responsibility of the customer. Conditions not covered under warranty are:

- (1) Corrosion due to electrolysis
- (2) Cracking of the tank due to freezing water
- (3) Routine maintenance that may be required

The foregoing warranty and condition shall apply to any repaired, reworked, or replaced products, part or component supplied by SEAWARD and shall in no event be liable to BUYER or BUYER'S customers for any incidental or consequential damages, or loss of use, or other losses, however occasioned.

Implied warranties of merchantability and of the fitness of the product for any purpose are warranted for a period of two years on parts and labor.

SEAWARD makes no warranties, expressed or implied after that time.

Some states do not allow limitation on how long an implied warranty lasts or for the exclusion or limitations of incidental or consequential damages, therefore, the above limitations may not apply to you.

This warranty is extended to the original purchaser only, unless purchased for purpose of resale. This warranty gives you specific legal rights, and you may also have other rights which vary from state to state.

Seaward Products

REPAIR PARTS

Repair parts listed herein may be ordered through Seaward Products. Seaward Distributors and Dealers, or Dealer's Authorized Service Centers. All parts will be shipped at prevailing prices.

When ordering repair parts, please give the following information:

- (1) The part number
- (2) The part description
- (3) The model number of the water heater
- (4) The serial number of the water heater

The model number and serial number of the water heater will be found on the rating plate located on the front panel. For the Authorized Service Center nearest you, please contact Seaward Products.

Seaward Products

3721 Capitol Avenue
Whittier, CA 90601-1732
Tel. (562) 699-7997 Fax. (562) 699-0908
www.seawardproducts.com

