



SERVICE MANUAL
Volume 5

System

LEWMAR

Introduction

Lewmar is the world's leading manufacturer of yacht winches. Our manufacturing facilities set the highest standards in quality materials and performance. Each Lewmar winch is tested to ensure that at all stages in the manufacturing process it conforms to the Lewmar requirements of dimensional accuracy, rated strength and operating efficiency. Our winches are approved to Lloyds standards and in practice are in excess of them.

Lewmar winches are constantly being tested in the latest racing competition, aboard leading ocean racers around the world and, whether racing or cruising, they are rated for their long life and performance.

However, as with any precision engineered assembly, Lewmar winches need regular maintenance to operate at peak efficiency and, without this attention, permanent damage and premature wear can result.

This Manual gives the most complete details of the sequence and techniques required to dismantle completely, service and assemble each winch in the Lewmar range.

Lewmar has a worldwide network of offices and distributors who carry stocks of spare parts and spare kits. Expert advice and assistance is available for any servicing or repair problem.

Warranty Details

Lewmar winches have been developed over many years by extensive testing aboard the world's finest ocean racers, long distance cruising yachts and match racing yachts such as 12 metres. They are manufactured to quality standards in excess of those required by Lloyds and only the finest materials are used.

If installed, used and maintained as described in this Manual they will give outstanding performance.

Lewmar undertake that any winch which proves defective in materials or workmanship within one year of the date of supply will be repaired or replaced FREE OF CHARGE provided that the winch is returned by the registered owner to the nearest Lewmar office or distributor for examination. Lewmar reserve all rights on determining the nature of the alleged fault and their decision is final.

Any warranty expressed or implied is ineffective unless the winch has been installed, used and regularly serviced in accordance with our instruction.

Service Notes

For satisfactory long term performance and product life these winches must be given the routine and full maintenance procedure described below.

- MONTHLY:** All Lewmar winches should be hosed down with fresh water then lightly oiled and greased as detailed in the separate free leaflet, "How to service your Lewmar Winch".
- TWO OR THREE TIMES DURING ACTIVE SAILING SEASON:** All Lewmar winches should be stripped, cleaned and relubricated.
- AT THE END OF EACH SAILING SEASON OR BEFORE STARTING THE NEW SEASON:** All Lewmar winches should be completely stripped, cleaned, thoroughly checked for damage, lubricated and reassembled as detailed in this Service Manual.

Dismantling

Lewmar winches are simple to dismantle and are designed for easy maintenance. The exploded view drawings show how the component parts can be removed easily from each winch.

Assembly

Winches must be assembled in the reverse sequence to the order of dismantling.

Mounting

All winches must be mounted using the correct size and type of retaining bolts. Having decided on the correct winch position, the drum must be removed as detailed in the maintenance instructions for mounting. The winch must be mounted on a flat clean surface.

The hole centres for the winch retaining bolts must be marked off and drilled separately. The winch should be bedded on a LIGHT coating of sealing compound to stop leaks — too much compound gets in the gears and pawls.

The winch retaining fastenings must be securely tightened (but not overtightened). The winch is self draining and care must be taken to ensure the drain holes are not blocked.

Handles

All current winches accept any standard international handle (Lewmar red grip handle).

Recommended Lubricants

Grease

Lewmar Grease 7010 (Lubriplate Marine Lube 'A', etc.)

Oil

Light Machine Oil (3-in-1 or equivalent)

Service and Spares

Full service facilities for Lewmar winches are provided at our factory and subsidiary companies and by our distributors and service centres worldwide.

A full listing is provided on the inside back cover.

Parts pricing is subject to change. Apply to your nearest Lewmar office or distributor for current price lists.

Contents Volume V

	Introduction Date	Page (Mod.)	No.
Single Speed Winches			
6 and 7	Jan 1976	(July 86)	3
8	Jan 1976	(July 86)	4
Two Speed Winches			
16	Mar 1984		5
24, 30 and 40	Mar 1984		6
43/46	Jan 1984		7
52	Dec 1984		8
Three Speed Winches			
48	Jan 1981		9
55	Jan 1981		10
65	Jan 1981		11
Self-Tailing Winches			
16	Jan 1984		12
30	Mar 1983		13
40	Jan 1984		14
43/46	Mar 1983		15
48	Jan 1981		16
52	Dec 1984		17
55	Jan 1981		18
65	Jan 1981		19
Halliard Reel Winches			
1	Jan 1976		20
Owners Servicing Log			21
Further Information			22
Lewmar Subsidiary Addresses and Lewmar Guarantee			23



Lloyd's Certificate

Lloyd's make a very careful examination of the material, design, construction, quality control and test procedures used by Lewmar and approved all the existing systems without alteration. Lewmar's existing standards proved to be higher than were required by Lloyd's.

Spares Kits

7001 **Basic Winch Servicing Kit** (4 circlips, pawls, pawl springs)

7002 **Winch Servicing Kit** (4 circlips, 8 pawls, 12 pawl springs, 3 keys, 2 pan head screws - self tailers)

7003 **Three Speed Winch Servicing Kit**

7009 **Allen Key set**

7010 **Grease, Packed in handy 100g plastic tube.**

7011 **Grease, Packed in handy 300 gm plastic tub.**

Packed in handy 100g plastic tubes, or 300 gm tubs, this waterproof grease contains solid activation which aids the load carrying characteristics of a winch. It is also suitable for trailer wheel bearings, steering gear, hydraulic equipment, outboard engines and many other marine applications.

7012 **Assembly Paste, Packed in a handy 300 gm tub.**

Ask your nearest Dealer/Distributor for a copy of the "How to Service your Lewmar Winch".

Nos.6/7

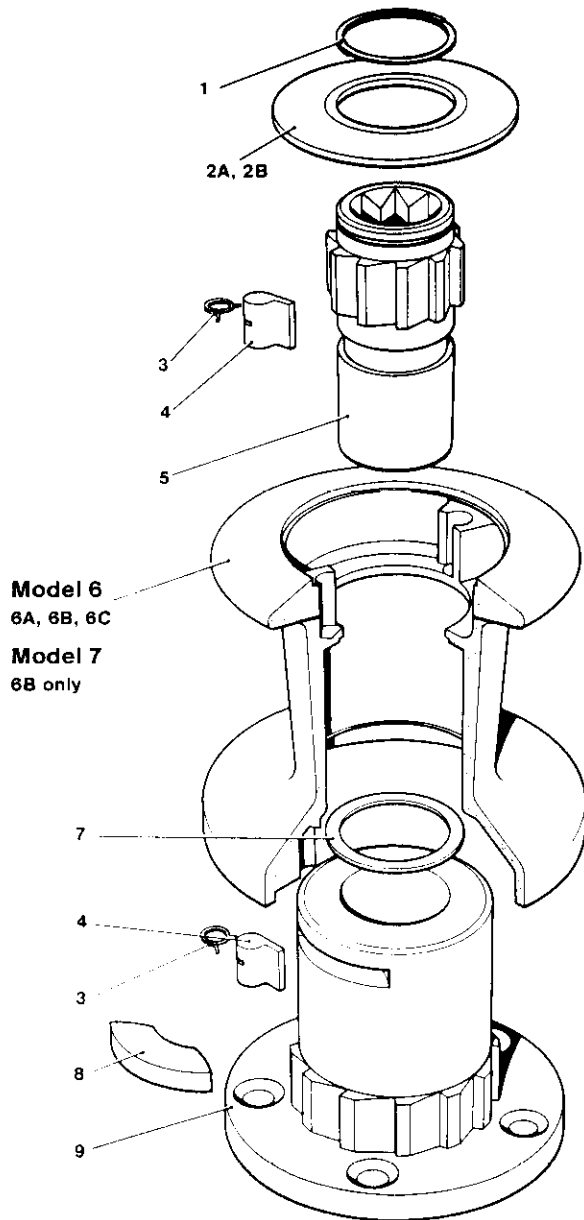

Model 6
6A, 6B, 6C

Model 7
6B only

Model 7B, 7C only

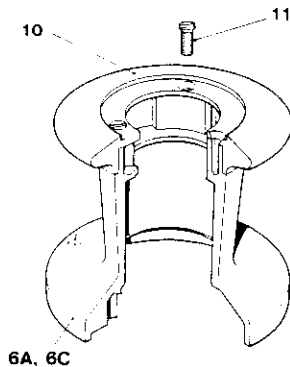

No. 6 1 Speed Winch

Item No.	Part No.	Description	No. Off
1	B2075	Circlip	1
2A	15000388	Top Cap Alloy Drum	1
2B	18000048	Top Cap - Chrome & Br Drum	1
3	1260/7	Pawl Spring	4
4	1260/8	Pawl	4
5	15000148	Spindle	1
6A	15006102	Drum - Chrome	1
6B	15000363	Drum - Alloy	1
6C	15000660	Drum - Bronze	1
7	15006004	Washer	1
8	15006005	Key	1
9	15000144	Centre Stem	1

No. 7 1 Speed Winch

Item No.	Part No.	Description	No. Off
1	B2075	Circlip	1
2A	15000443	Top Cap - Alloy Drum	1
2B	15000478	Top Cap - Chrome & Br Drum	1
3	1260/7	Pawl Spring	4
4	1260/8	Pawl	4
5	15000148	Spindle	1
6A	15000650	Drum - Chrome	1
6B	15000364	Drum - Alloy	1
6C	15000661	Drum - Bronze	1
7	15006004	Washer	1
8	15010005	Key	1
9	15000143	Centre Stem	1
10	15000652	Crown	1
11	15000527	Screw	3

No.8

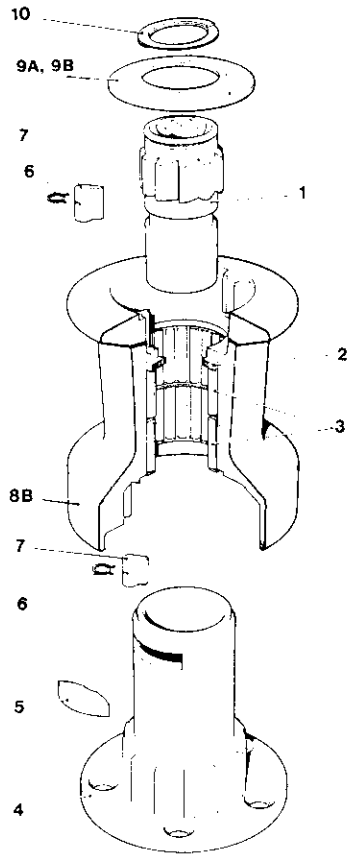

Model 8B, 8C only

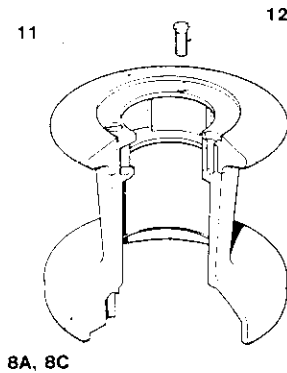

No. 8 1 Speed Winch

Item No.	Part No.	Description	No. Off
1	15008003	Spindle	1
2	15008004	Drum Washer	1
3	15008007	Roller Bearing	2
4	15008001	Centre Stem	1
5	15008005	Key	1
6	1260/7	Pawl Spring	4
7	1260/8	Pawl	4
8A	15000650	Drum - Chrome	1
8B	15000364	Drum - Alloy	1
8C	15000661	Drum - Bronze	1
9A	15000434	Top Cap - Alloy	1
9B	15000478	Top Cap - Chrome & Br Drum	1
10	B2075	Circlip	1
11	15000651	Crown	1
12	15000527	Screw	3

No.16

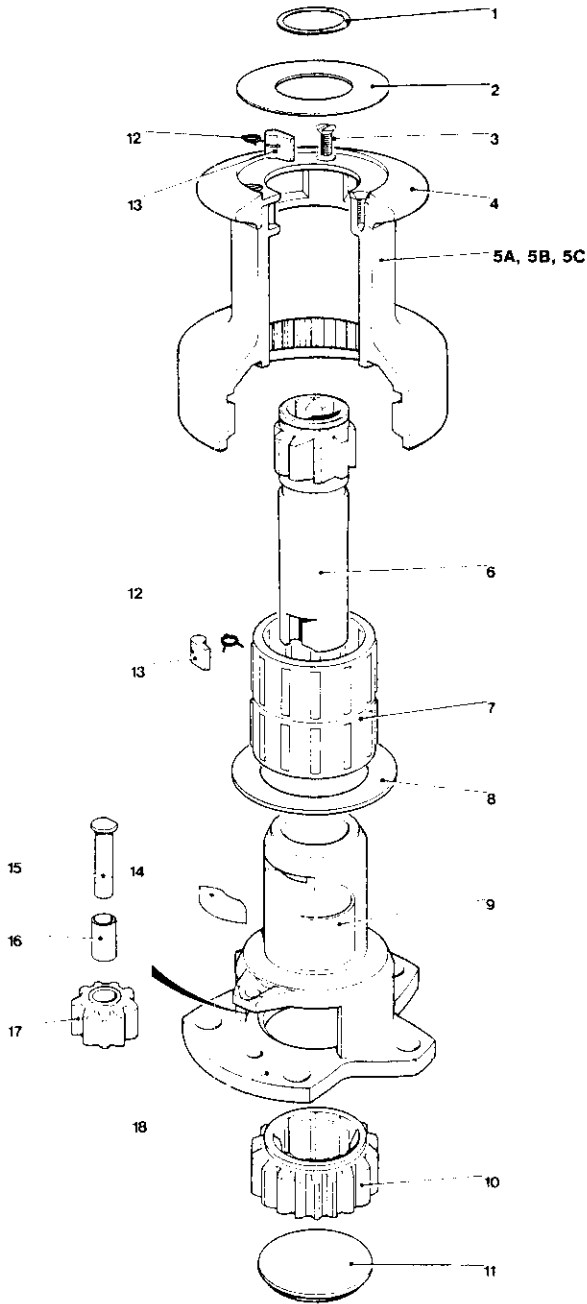

No. 16 2 Speed Winch

Item No.	Part No.	Description	No. Off
1	B2075	Circlip	1
2	15000478	Top Cap	1
3	15000527	Csk Hd Posidriv Screw M5 x 12mm Long	3
4	15000457	Crown	1
5A	15000453	Drum - Chrome	1
5B	15000454	Drum - Alloy	1
5C	15000662	Drum - Bronze	1
6	15000829	Spindle Assy.	1
7	15008007	Roller Bearing	2
8	15000466	Drum Washer	1
9	15000377	Main Spindle Sleeve Fitted to Item 18	1
10	15000464	Ratchet Gear	1
11	15000461	Gear Retainer	1
12	1260/7	Pawl Spring	4
13	1260/8	Pawl	4
14	15008005	Key	1
15	15000463	Idler Spindle	1
16	15000133	Gear Spindle Sleeve	1
17	15000827	Idler Gear	1
18	15000450	Centre Stem	1

Nos. 24/30/40

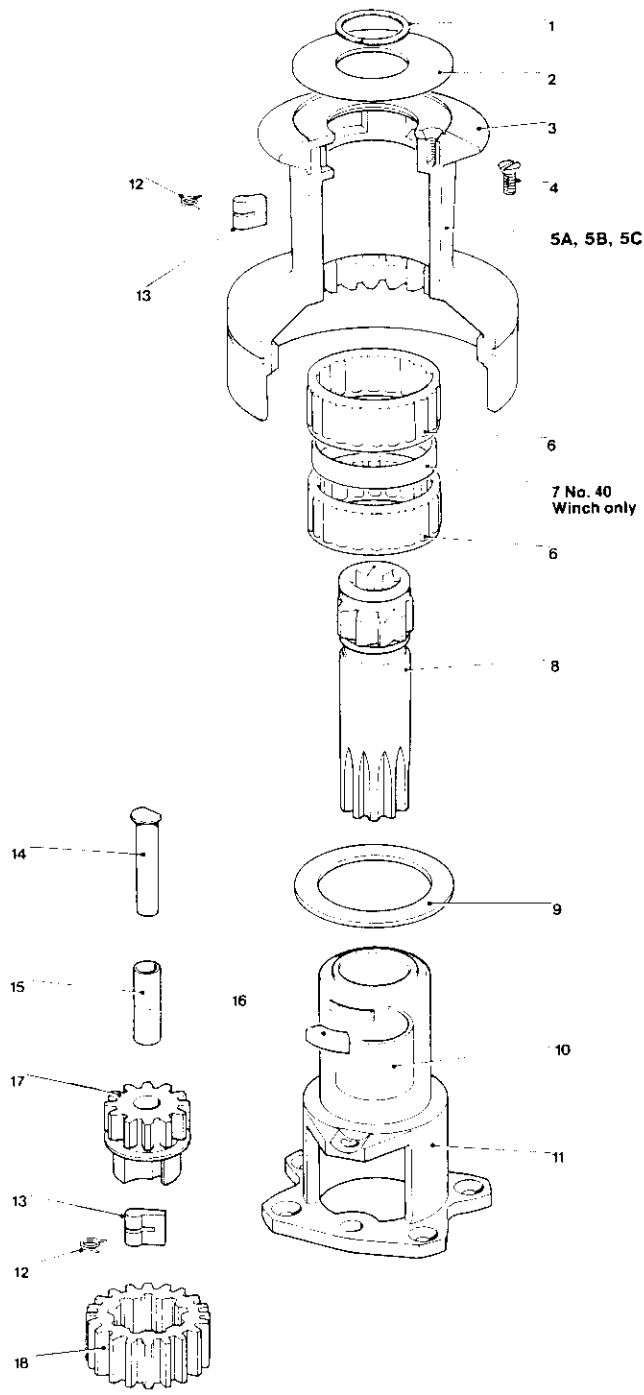

No. 24 2 Speed Winch

Item No.	Part No.	Description	No. Off
1	B2075	Circlip	1
2	15000478	Top Cap	1
3	15000474	Crown	1
4	15000527	Csk Hd Posidriv Screw M5 x 12mm Long	3
5A	15000471	Drum - Chrome	1
5B	15000472	Drum - Alloy	1
5C	15000663	Drum - Bronze	1
6	15008007	Roller Bearing	2
7	—	—	—
8	15000830	Spindle Assy.	1
9	15000376	Drum Washer	1
10	15000377	Main Spindle Sleeve Fitted to Item 11	1
11	15000473	Centre Stem	1
12	1260/7	Pawl Spring	4
13	1260/8	Pawl	4
14	15000423	Gear Spindle	1
15	15000378	Gear Spindle Sleeve	2
16	15008005	Key	1
17	15000477	Pawl Gear	1
18	15000476	Ratchet Gear	1

No. 30 2 Speed Winch

Item No.	Part No.	Description	No. Off
1	B2075	Circlip	1
2	15000433	Top Cap	1
3	15000374	Crown	1
4	15000527	Csk Hd Posidriv Screw M5 x 12mm Long	3
5A	15000448	Drum - Chrome	1
5B	15000447	Drum - Alloy	1
5C	15000664	Drum - Bronze	1
6	15008007	Roller Bearing	2
7	—	—	—
8	15000830	Spindle Assy.	1
9	15000466	Drum Washer	1
10	15000377	Main Spindle Sleeve Fitted to Item 11	1
11	15000467	Centre Stem	1
12	1260/7	Pawl Spring	4
13	1260/8	Pawl	4
14	15000385	Gear Spindle	1
15	15000378	Gear Spindle Sleeve	2
16	15008005	Key	1
17	15000470	Pawl Gear	1
18	15000469	Ratchet Gear	1

No. 40 2 Speed Winch

Item No.	Part No.	Description	No. Off
1	B2075	Circlip	1
2	15000433	Top Cap	1
3	15000495	Crown	1
4	15000527	Csk Hd Posidriv Screw M5 x 12mm Long	3
5A	15000492	Drum - Chrome	1
5B	15000492	Drum - Alloy	1
5C	15000665	Drum - Bronze	1
6	15008007	Roller Bearing	2
7	15000491	Spacer	1
8	15000831	Spindle Assy.	1
9	15000466	Drum Washer	1
10	15000377	Main Spindle Sleeve Fitted to Item 11	2
11	15000494	Centre Stem	1
12	1260/7	Pawl Spring	4
13	1260/8	Pawl	4
14	15000486	Gear Spindle	1
15	15000378	Gear Spindle Sleeve	2
16	15008005	Key	1
17	15000490	Pawl Gear	1
18	15000496	Ratchet Gear	1

Nos. 43/46

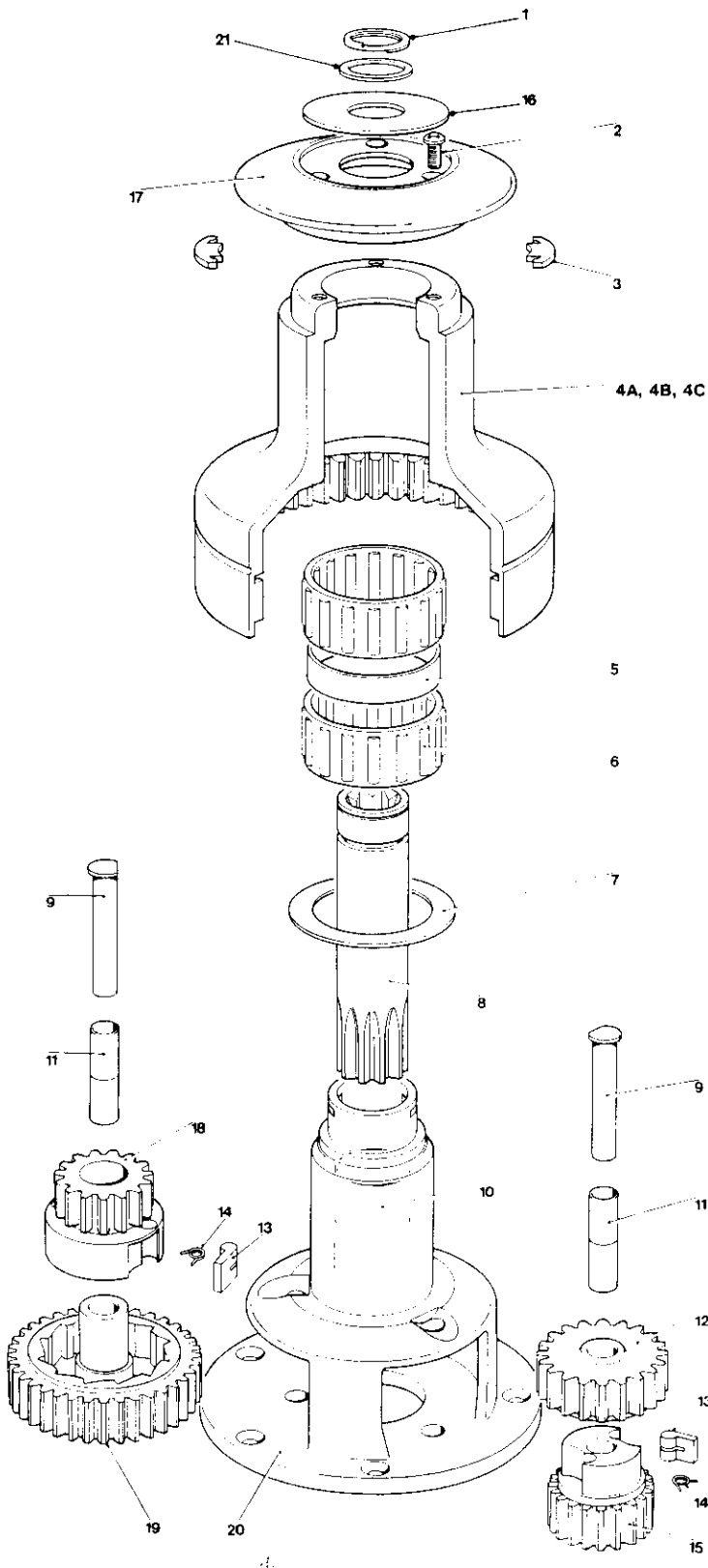

No. 43 2 Speed Winch

Item No.	Part No.	Description	No. Off
1	B2075	Circlip	1
2	B0325	Pan Hd Posidriv Screw M5 x 12mm Long	3
3	15000432	Collet	2
4A	15000410	Drum - Chrome	1
4B	15000411	Drum - Alloy	1
4C	15000666	Drum - Bronze	1
5	1501008	Spacer	1
6	15010007	Roller Bearing	2
7	15034638	Drum Washer	1
8	15000832	Spindle	1
9	15000422	Gear Spindle	2
10	15000377	Main Spindle Sleeve Fitted to Item 20	2
11	15000398	Gear Spindle Sleeve	4
12	15000418	Ratchet Gear	1
13	1260/8	Pawl	4
14	1260/7	Pawl Spring	4
15	15000397	Pawl Gear	1
16	15000433	Top Cap	1
17	15000416	Crown	1
18	15000419	Pawl Gear	1
19	15000417	Ratchet Gear	1
20	15000409	Centre Stem	1
21	15000684	Washer	1

No. 46 2 Speed Winch

Item No.	Part No.	Description	No. Off
1	B2075	Circlip	1
2	B0325	Pan Hd. Posidriv Screw M5 x 12mm Long	3
3	15000432	Collet	2
4A	15000391	Drum - Chrome	1
4B	15000392	Drum - Alloy	1
4C	15000667	Drum - Bronze	1
5	15000404	Spacer	1
6	15044121	Cage Assy.	2
7	15044116	Drum Washer	1
8	15000833	Spindle	1
9	15000394	Gear Spindle	2
10	15000377	Main Spindle Sleeve Fitted to Item 20	2
11	15000398	Gear Spindle Sleeve	4
12	15000396	Ratchet Gear	1
13	1260/8	Pawl	4
14	1260/7	Spring	4
15	15000397	Pawl Gear	1
16	15000433	Top Plate	1
17	15000430	Crown	1
18	15000393	Pawl Gear	1
19	15000395	Ratchet Gear	1
20	15000400	Centre Stem	1
21	15000684	Washer	1

No.55

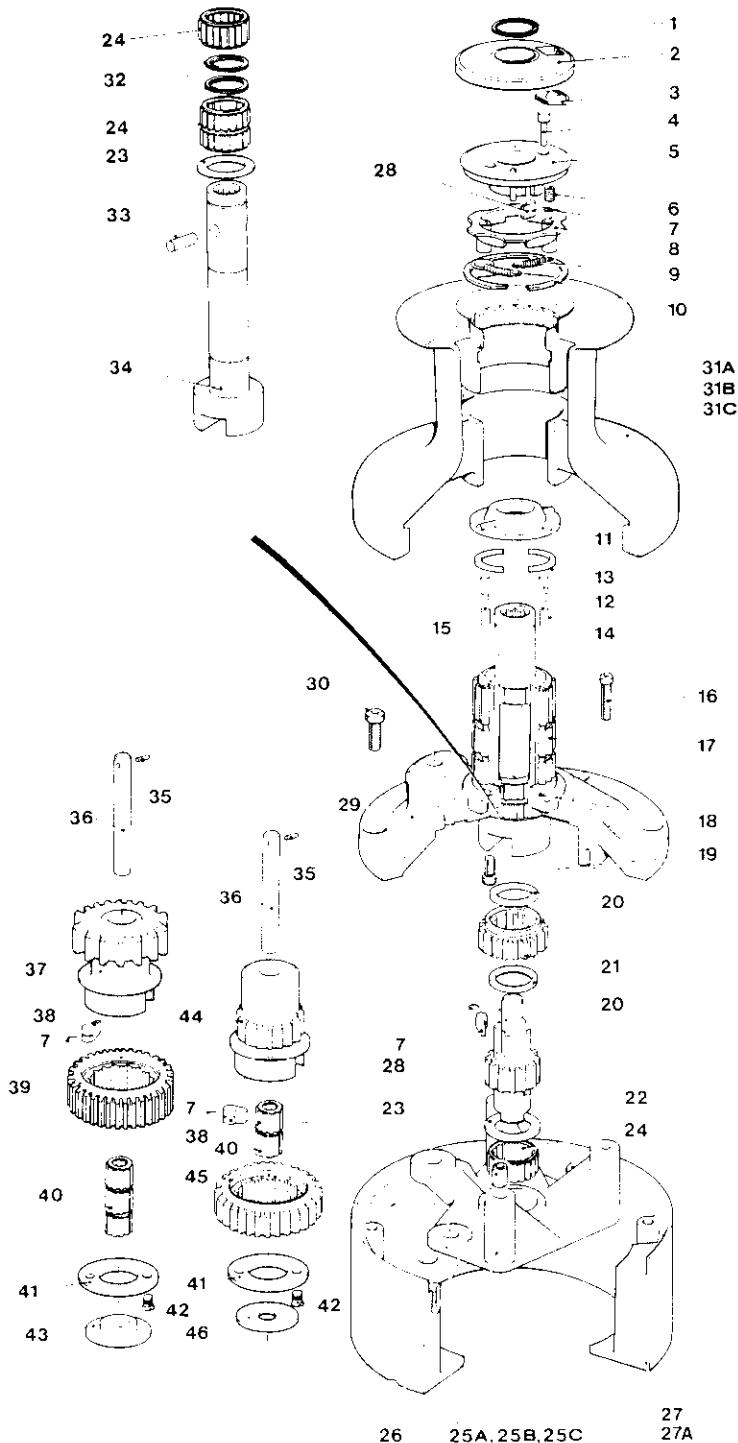

No. 55 3 Speed Winch

Item No.	Part No.	Description	No. Off
1	B 2075	Circlip	1
2	15055106	Top Cap Cover	1
3	15044114	Push Button	1
4	15044111	Plunger	1
5	15044104	Top Cap Assembly	1
6	15044112	Spring	1
7	15000466	Drum Washer	1
8	15044106	Closing Ring	1
9	15044113	Spring	2
	15044115	Spring - Anchor Pin	2
10	B 2083	Circlip	1
11	15044105	Clutch Plate	1
12	15137203	Plunger	2
13	15044118	Collet	2
14	15137204	Spring	2
15	15000256	Centre Stem Upper	1
16	B 0698	Skt. Hd. Cap Screw - $\frac{5}{8}$ " UNC \times $\frac{1}{2}$ " Long	3
17	15044121	Roller Bearing	3
18	15000287	Drum Washer	1
19	B 0737	Skt. Hd. Cap Screw - $\frac{5}{8}$ " UNC \times $\frac{1}{2}$ " Long	6
20	15000303	Spacer	2
21	15000259	Ratchet Gear	1
22	15000234	Spindle Extension	1
23	15000024	Washer	2
24	15000019	Roller Bearing	4
25A	15000252	Bridge Piece	1
25B	15000053	Sleeve - Bridge Piece	1
25C	B 2401	Heli - Coil Insert	3
26	15065111	Hollow Dowel	2
27	15000265	Base	1
27A	B 2408	Heli - Coil Insert	4
28	1260/8	Pawl	4
29	15000251	Centre Stem Lower	1
30	B 0714	Skt. Hd. Cap Screw - $\frac{3}{8}$ " UNC \times $\frac{3}{4}$ " Long	4
31A	15000269	Drum - Bronze	1
31B	15000268	Drum - Alloy	1
31C	15000267	Drum - S. Steel	1
32	B 2086	Circlip	2
33	15044119	Drive Pin	1
34	15000266	Main Spindle	1
35	B 1501	Spiral Pin	2
36	15000236	Gear Spindle	2
37	15000262	Pawl Gear	1
38	1264/8	Pawl	4
39	15000261	Ratchet Gear	1
40	15000017	Roller Bearing	5
41	1302/17	Retaining Plate	2
42	B 0511	Csk. Screw - 2BA \times $\frac{3}{8}$ " Long	4
43	15000306	Flanged Bush	1
44	15000342	Idler Gear	1
45	15000260	Ratchet Gear	1
46	15000247	Washer	1

No.65

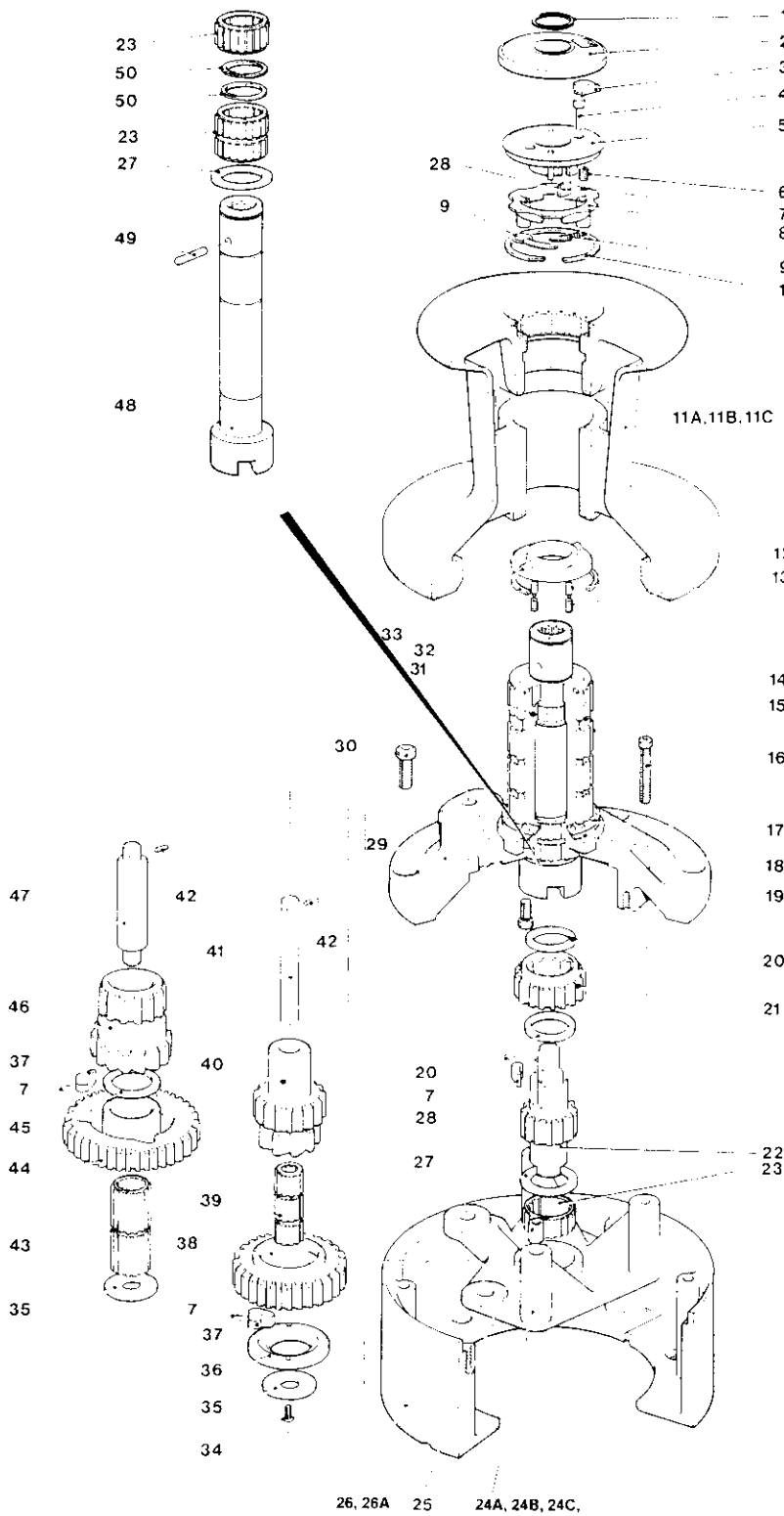

No. 65 3 Speed Winch

Item No.	Part No.	Description	No. Off
1	B 2075	Circlip	1
2	15065106	Top Cap Cover	1
3	15044114	Push Button	1
4	15044111	Plunger	1
5	15044104	Top Cap Assembly	1
6	15044112	Spring	1
7	1260/7	Pawl Spring	9
8	15044106	Closing Ring	1
9	15044113	Spring	2
10	B 2083	Circlip	1
11A	15000206	Drum - Bronze	1
11B	15000207	Drum - Alloy	1
11C	15000208	Drum - St. Steel	1
12	15137203	Plunger	2
13	15137204	Spring	2
14	15065115	Spacer	1
15	15044121	Roller Bearing	4
16	B 0698	Skt. Hd. Cap Screw - $\frac{5}{16}$ " UNC x $1\frac{1}{2}$ " Long	3
17	18080015	Thrust Bearing	1
18	15000082	Drum Washer	1
19	B 0730	Skt. Hd. Cap Screw - $\frac{5}{16}$ " UNC x $\frac{3}{8}$ " Long	8
20	15000303	Spacer	2
21	15000242	Ratchet Gear	1
22	15000241	Spindle Extension	1
23	15000019	Roller Bearing	4
24A	15000048	Bridge Piece	1
24B	15000053	Sleeve - Bridge Piece	1
24C	B 2401	Heli - Coil Insert	3
25	15065111	Hollow Dowel	2
26	15000197	Base	1
26A	B 2408	Heli - Coil Insert	6
27	15000024	Washer	2
28	1260/8	Pawl	4
29	15000049	Centre Stem Lower	1
30	B 0714	Skt. Hd. Cap Screw - $\frac{3}{8}$ " UNC x $\frac{3}{4}$ " Long	6
31	15000195	Centre Stem Upper	1
32	15044118	Collet	2
33	15044105	Clutch Plate	1
34	B 0511	Csk. Screw - 2 BA x $\frac{3}{8}$ " Long	2
35	15000247	Washer	2
36	15000023	Retainer	1
37	1264/8	Pawl	5
38	15000040	Pawl Gear	1
39	15000017	Roller Bearing	3
40	15000245	Idler Gear	1
41	15000240	Gear Spindle	1
42	B 1501	Spirol Pin	2
43	15000018	Roller Bearing	2
44	15000244	Pawl Gear	1
45	15000246	Washer	1
46	15000243	Ratchet Gear	1
47	15000239	Gear Spindle	1
48	15000198	Spindle	1
49	15000119	Drive Pin	1
50	B 2086	Circlip	2

No.16ST

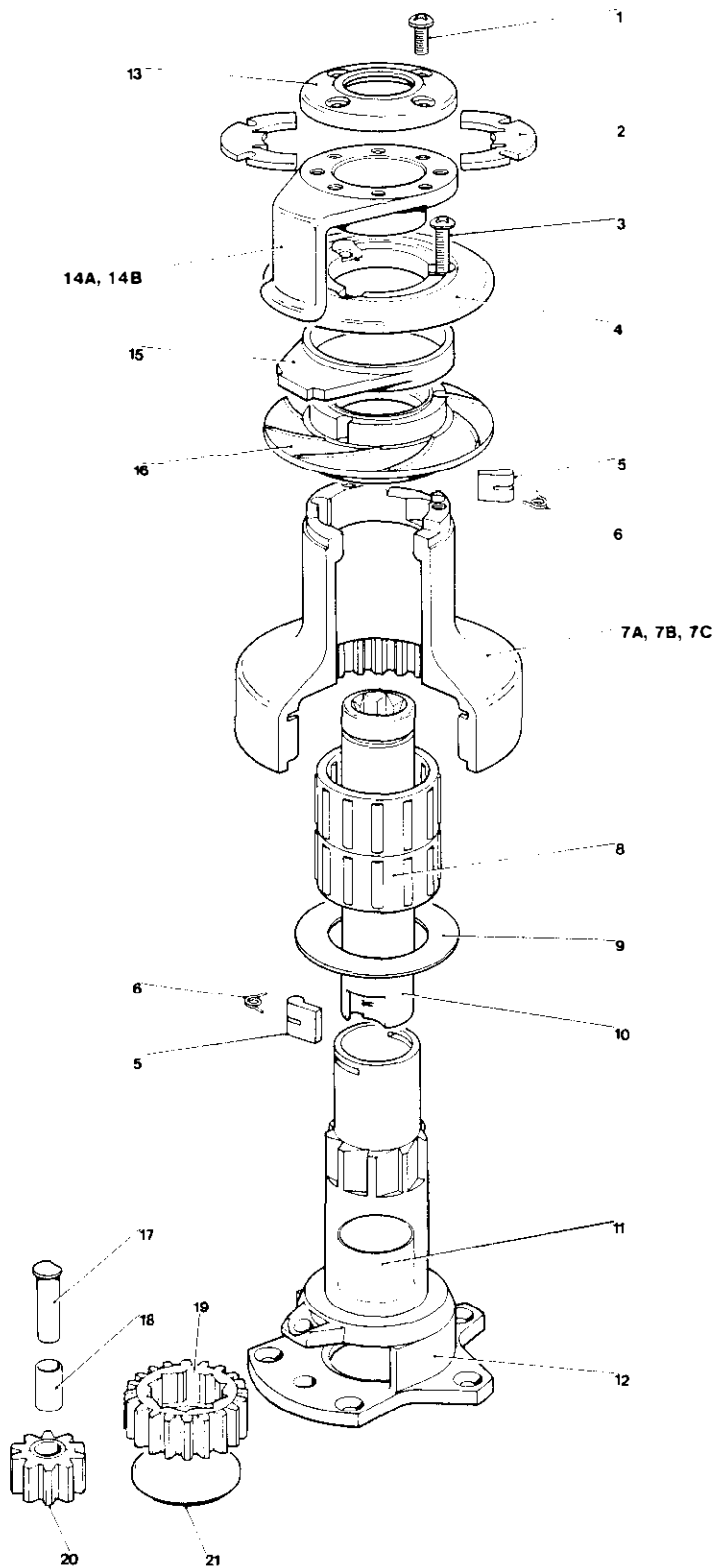

No. 16 1 Speed Self Tailing Winch

Item No.	Part No.	Description	No. Off
1	B0325	Pan Hd Posidriv Screw M5 x 12mm Long	4
2	15000387	Collet	2
3	15000532	Pan Hd Posidriv Screw M5 x 30mm Long	3
4	15000456	Upper Crown	1
5	1260/8	Pawl	5
6	1260/7	Pawl Spring	5
7A	15000451	Drum -	1
7B	15000452	Drum - Alloy	1
7C	15000668	Drum - Bronze	1
8	15008007	Roller Bearing	2
9	15000466	Drum Washer	1
10	15000462	Spindle	1
11	15000377	Main Spindle Sleeve Fitted to Item 12	1
12	15000449	Centre Stem	1
13	15000460	Top Cap	1
14A	15000458	Feeder Arm - Chrome	1
14B	15000671	Feeder Arm - Bronze	1
15	15000459	Stripper Ring	1
16	15000455	Lower Crown	1
17	15000463	Gear Spindle	1
18	15000133	Gear Spindle Sleeve	1
19	15000464	Ratchet Gear	1
20	15000827	Idler Gear	1
21	15000461	Gear Retainer	1

No.30ST

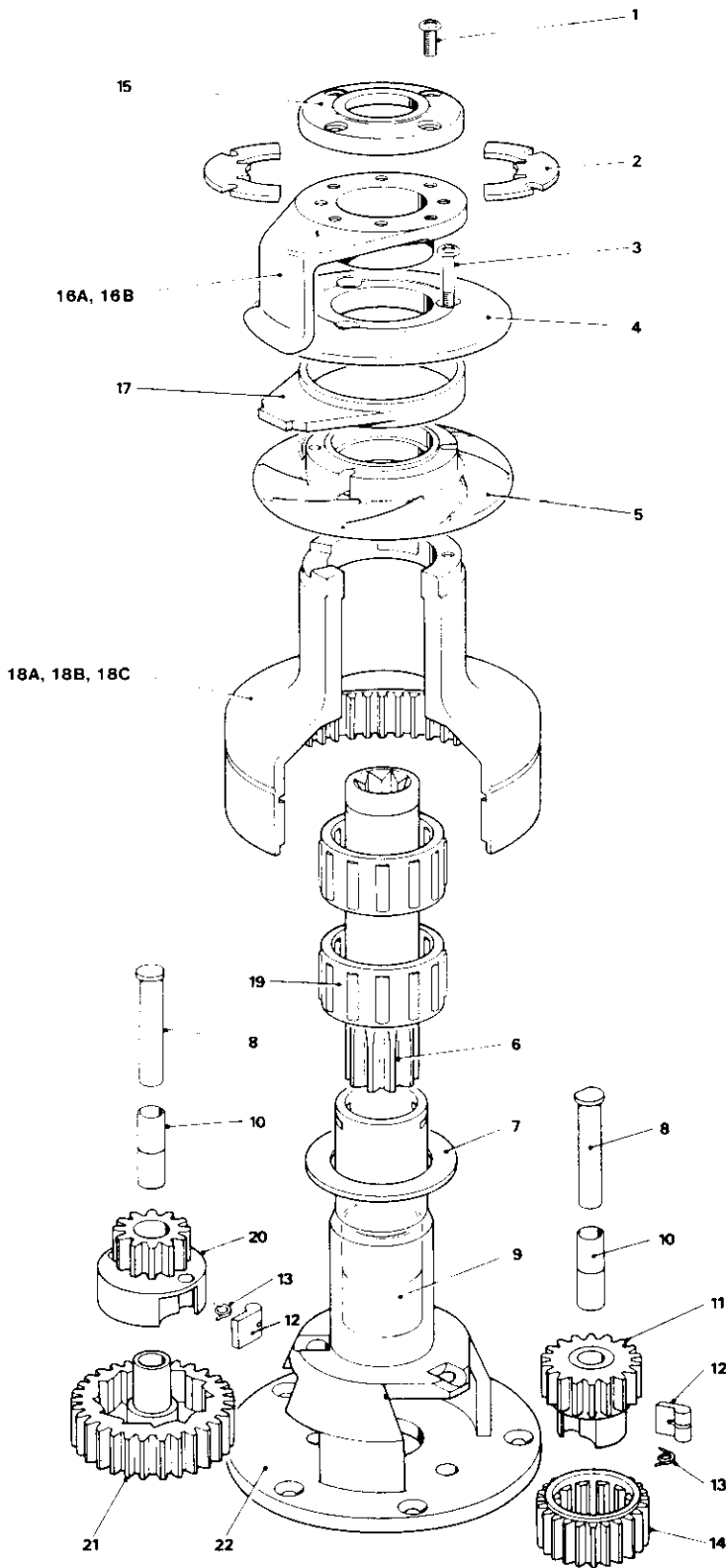

No. 30 2 Speed Self Tailing Winch

Item No.	Part No.	Description	No. Off
1	B0325	Pan Hd Posidriv Screw M5 x 12mm Long	4
2	15000387	Collet	2
3	B0326	Pan Hd Posidriv Screw M5 x 30mm Long	3
4	15000372	Upper Crown	1
5	15000373	Lower Crown	1
6	15000835	Spindle	1
7	15000466	Drum Washer	1
8	15000385	Gear Spindle	2
9	15000377	Main Spindle Sleeve	2
9	15000377	Main Spindle Sleeve Fitted to Item 22	2
10	15000378	Gear Spindle Sleeve	4
11	15000383	Pawl Gear	1
12	1260/8	Pawl	4
13	1260/7	Pawl Spring	4
14	15000381	Ratchet Gear	1
15	15000379	Top Cap	1
16A	15000371	Feeder Arm - Chrome	1
16B	15000672	Feeder Arm - Bronze	1
17	15000375	Stripper Ring	1
18A	15000384	Drum - Chrome	1
18B	15000370	Drum - Alloy	1
18C	15000669	Drum - Bronze	1
19	15008007	Roller Bearing	2
20	15000382	Pawl Gear	1
21	15000380	Ratchet Gear	1
22	15000365	Centre Stem	1

No. 40ST

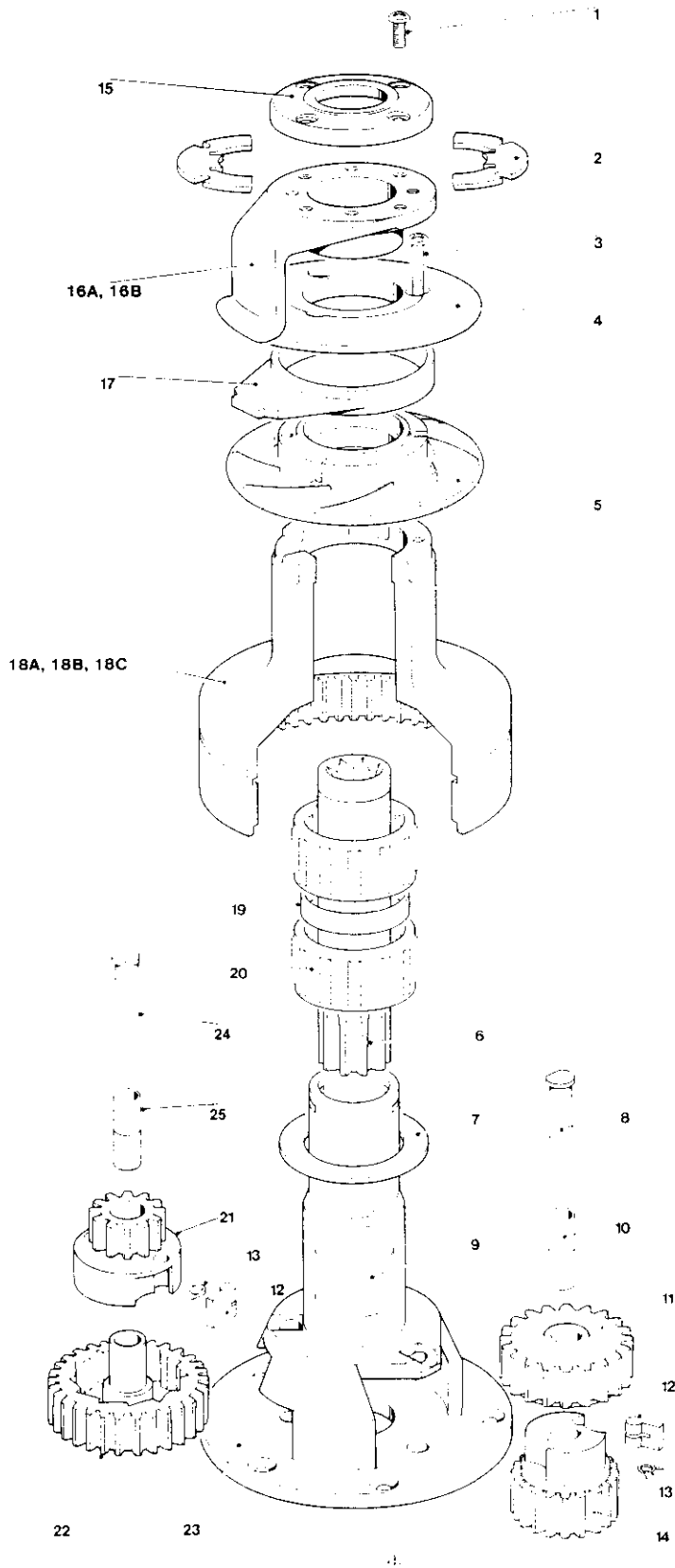

No. 40 2 Speed Self Tailing Winch

Item No.	Part No.	Description	No. Off
1	B0325	Pan Hd Posidriv Screw M5 x 12mm Long	4
2	15000387	Collet	2
3	B0325	Pan Hd Posidriv Screw M5 x 30mm Long	3
4	15000482	Upper Crown	1
5	15000373	Lower Crown	1
6	15000836	Spindle	1
7	15000466	Drum Washer	1
8	15000486	Gear Spindle	1
9	15000377	Main Spindle Sleeve Fitted Item 23	2
10	15000378	Gear Spindle Sleeve	2
11	15000489	Ratchet Gear	1
12	1260/8	Pawl	4
13	1260/8	Pawl Spring	4
14	15000490	Pawl Gear	1
15	15000379	Top Cap	1
16A	15000371	Feeder Arm - Chrome	1
16B	15000672	Feeder Arm - Bronze	1
17	15000375	Stripper Ring	1
18A	15000483	Drum - Chrome	1
18B	15000484	Drum - Alloy	1
18C	15000670	Drum - Bronze	1
19	15000491	Bearing Spacer	1
20	150008007	Bearing	2
21	15000488	Pawl Gear	1
22	15000487	Ratchet Gear	1
23	15000485	Centre Stem	1
24	15000620	Gear Spindle	1
25	15000398	Gear Spindle Sleeve	2

Nos. 43/46ST

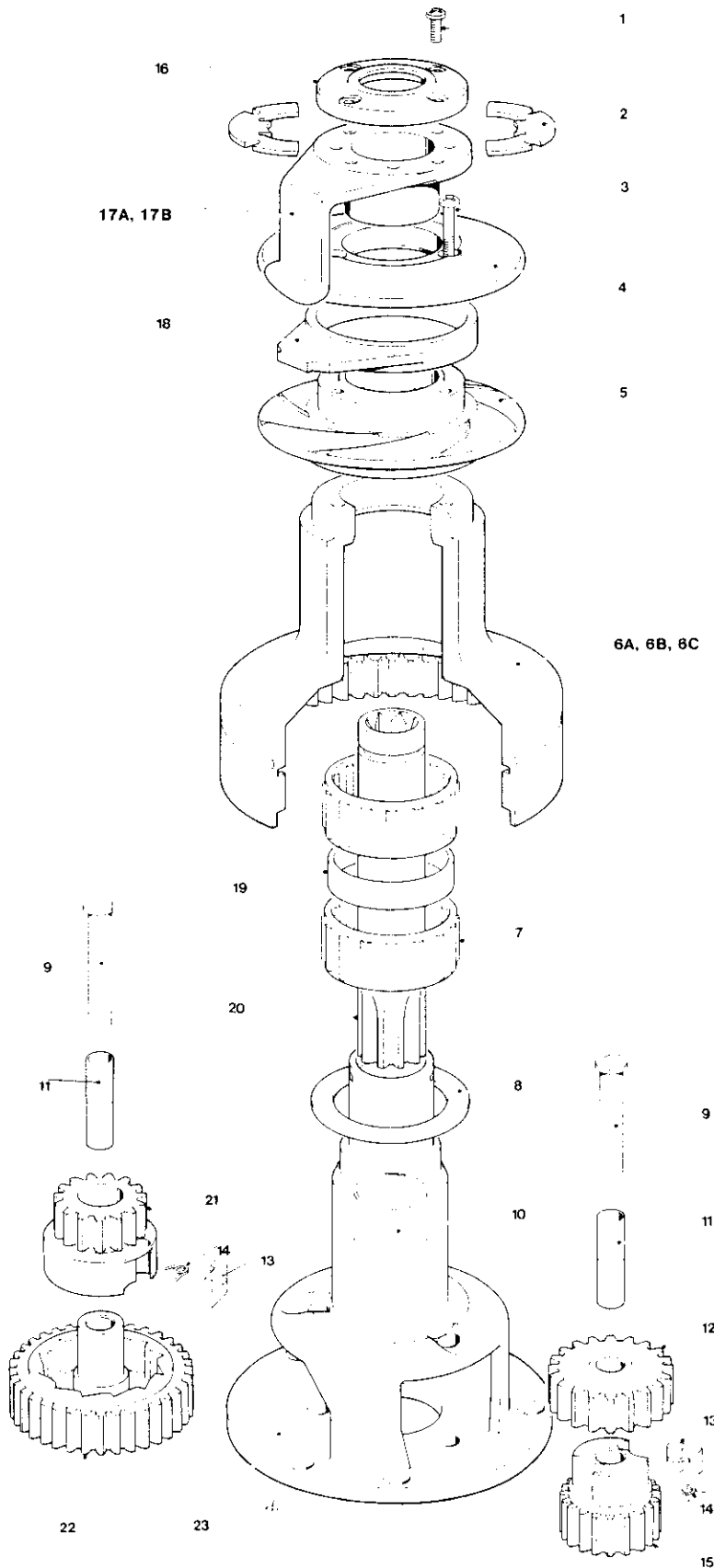

No. 43 2 Speed Self Tailing Winch

Item No.	Part No.	Description	No. Off
1	B0325	Pan Hd Posidriv Screw M5 x 12mm Long	4
2	15000387	Collet	2
3	B0325	Pan Hd Posidriv M5 x 40mm	3
4	15000414	Upper Crown	1
5	15000415	Lower Crown	1
6A	15000410	Drum - Chrome	1
6B	15000411	Drum - Alloy	1
6C	15000666	Drum - Bronze	1
7	1501007	Roller Bearing	2
8	15034638	Drum Washer	1
9	15000422	Gear Spindle	2
10	15000377	Main Spindle Sleeve Fitted with Item 23	2
11	15000398	Gear Spindle Sleeve	4
12	15000418	Ratchet Gear	1
13	1260/8	Pawl	4
14	1260/7	Spring	4
15	15000397	Pawl Gear	1
16	15000379	Top Cap	1
17A	15000412	Feeder Arm - Chrome	1
17B	15000673	Feeder Arm - Bronze	1
18	15000413	Stripper Ring	1
19	15010008	Spacer	1
20	15000837	Main Spindle	1
21	15000419	Pawl Gear	1
22	15000417	Ratchet Gear	1
23	15000408	Centre Stem	1

No. 46 2 Speed Self Tailing Winch

Item No.	Part No.	Description	No. Off
1	B0325	Pan Hd. Posidriv Screw M5 x 12mm Long	4
2	15000387	Collet	2
3	B0327	Pan Hd. Posidriv M5 x 40mm	3
4	15000403	Upper Crown	1
5	15000402	Lower Crown	1
6A	15000391	Drum - Chrome	1
6B	15000392	Drum - Alloy	1
6C	15000667	Drum - Bronze	1
7	15044121	Roller Bearing	2
8	15044116	Drum Washer	1
9	15000394	Gear Spindle	2
10	15000377	Main Spindle Sleeve Fitted with Item 23	3
11	15000398	Gear Spindle Sleeve	4
12	15000396	Ratchet Gear	1
13	1260/8	Pawl	4
14	1260/7	Pawl Spring	4
15	15000397	Pawl Gear	1
16	15000379	Top Cap	1
17A	15000389	Feeder Arm - Chrome	1
17B	15000674	Feeder Arm - Bronze	1
18	15000390	Stripper Ring	1
19	15000404	Spacer	1
20	15000838	Main Spindle	1
21	15000393	Pawl Gear	1
22	15000395	Ratchet Gear	1
23	15000399	Centre Stem	1

No.48ST

No. 48 2 Speed Self Tailing Winch

Item No.	Part No.	Description	No. Off
1	15044639	Top Cap	1
2	B0729	Skt. Hd. Cap Screw - 1/4" UNC x 1 1/2" Long	3
3	15048644	Upper Crown Plate	1
4	15048649	Stripper Ring	1
4A	15048641	Stripper Ring Insert	2
5	B0723	Skt. Hd. Cap Screw - 1/4" UNC x 1/2" Long	3
6	15048635	Lower Crown Plate	1
6A	B2405	Heli-Coil Insert	3
7A	15000097	Drum - Bronze	1
7B	15048502	Drum - Alloy	1
7C	15048602	Drum - St. Steel	1
8	15000308	Collar	1
9	15040605	Key	2
10	15044121	Roller Bearing	3
11	15000315	Centre Stem - Upper	1
12	15044116	Drum - Washer	1
13	15000014	Centre Stem - Lower	1
14	1300/21	Washer	1
15	15048633	Main Spindle	1
16	15025107	Spacer	1
17	1260/7	Pawl Spring	6
18	15000369	Ratchet Gear	1
19	15016107	Spindle End Cap	1
20	B0515	C'sk Screw - 1/4" UNC x 1/2" Long	1
21	1260/8	Pawl	2
22	B1516	Spirol Pin	2
23	15000016	Gear Spindle	1
24	1300/22	Washer	1
25	1300/SA2	Roller Bearing	3
26	1300/8	Pawl Gear	1
27	1300/5	Ratchet Gear	2
28	1264/7	Washer	2
29	1264/8	Pawl	4
30	15000015	Gear Spindle	1
31	15000019	Roller Bearing	1
32	1300/6	Pawl Gear	1
33	B0719	Skt. Hd. Cap Screw - 5/16" UNC x 3/4" Long	4
34	15044627	Flanged Bush	1
35	15048648	Stripper Arm	1
36	15044637	Split Collet	2
37	B0733	Skt. Hd. Cap Screw - 1/4" UNC x 3/8" Long	4

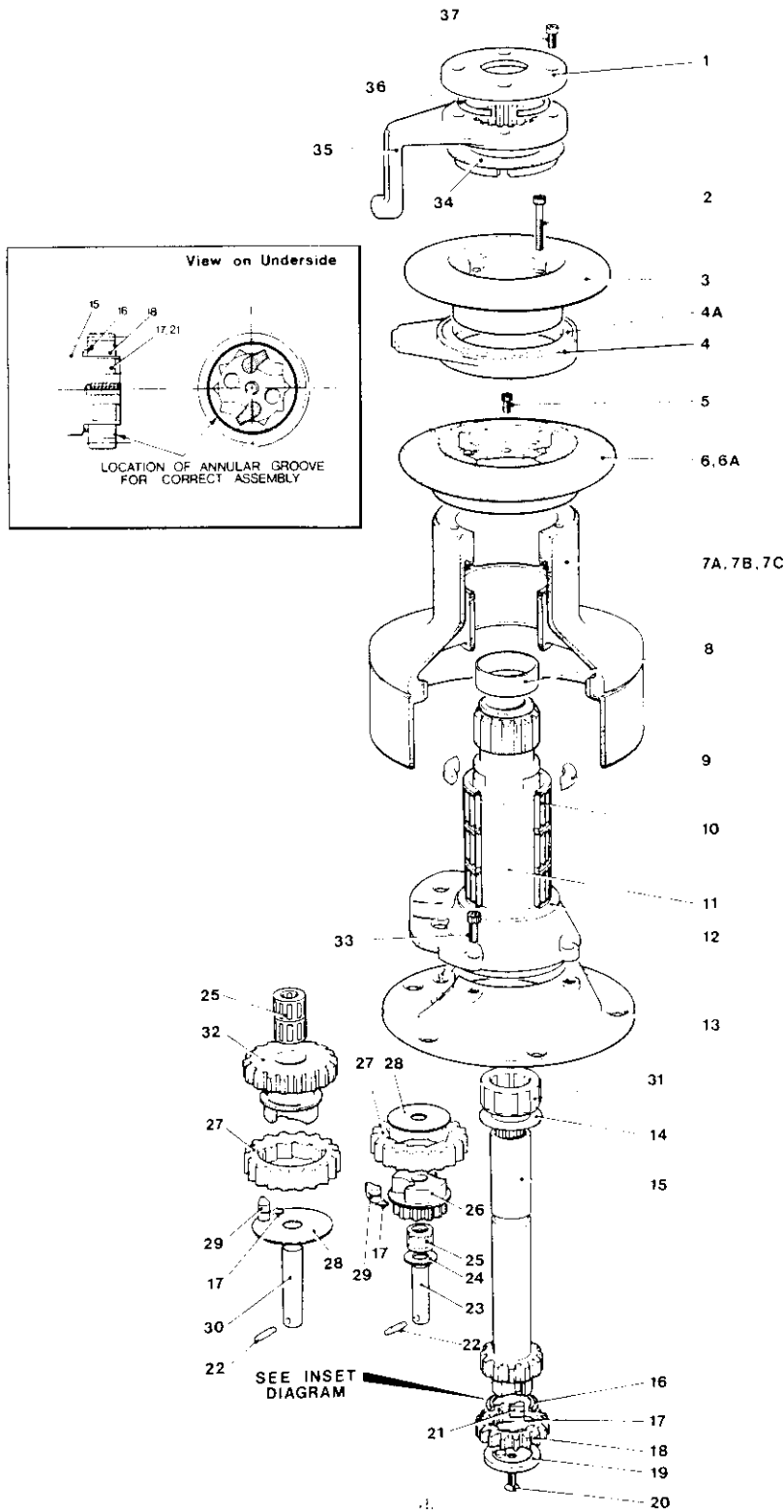

No.52/56ST

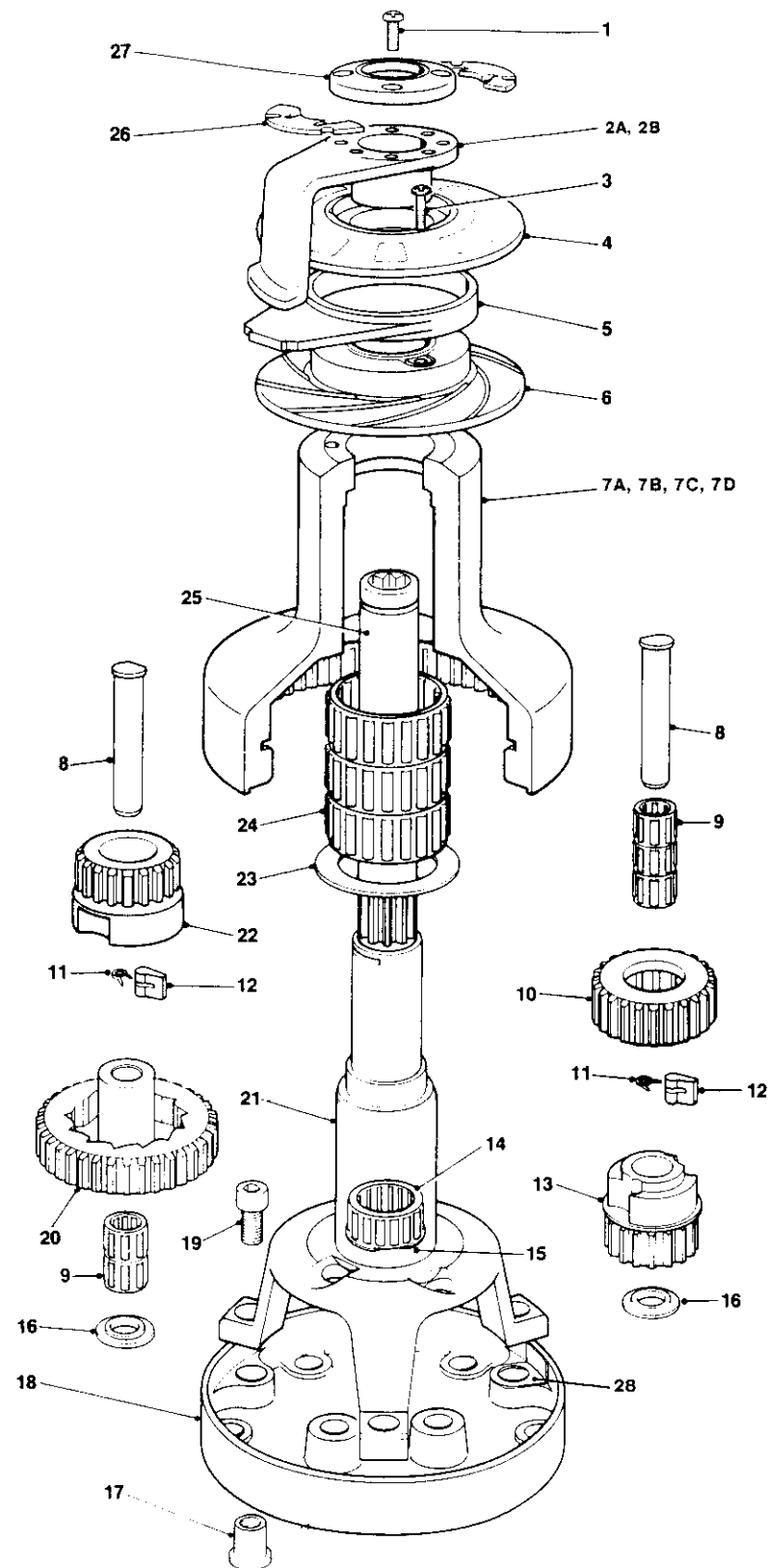

No. 52 2 Speed Self Tailing Winch

Item No.	Part No.	Description	No. Off
1	B0325	Pan Hd Pozidriv Screw M5 x 12mm Long	4
2A	15000637	Feeder Arm - Chrome	1
2B	15001028	Feeder Arm - Bronze	1
3	B0327	Pan Hd Pozidriv Screw M5 x 40mm Long	3
4	15000635	Upper Crown	1
5	15000638	Stripper Ring	1
6	15000636	Lower Crown	1
7A	15000633	Drum - Alloy	1
7B	18000095	Drum - Stainless Steel	1
7C	15000653	Drum - Chrome	1
7D	15000654	Drum - Bronze	1
8	15000645	Gear Spindle	2
9	15000017	Roller Bearing	5
10	15000627	Ratchet Gear	1
11	15000722	Pawl Spring	4
12	1264/8	Pawl	4
13	15000628	Pawl Gear	1
14	15000019	Roller Bearing	1
15	B2092	Spirolox Internal Ring	1
16	15000646	Flanged Washer	2
17	15000648	Hollow Dowel	3
18	15000634	Base	1
19	B0806	Skt Hd Csk Screw M10 x 25mm Long	3
20	15000625	Ratchet Gear	1
21	15000631	Centre Stem	1
22	15000626	Pawl Gear	1
23	15000644	Drum Washer	1
24	15044121	Roller Bearing	3
25	15000839	Main Spindle	1
26	15000387	Collet	2
27	15000379	Top Cap	1
28	15000655	Shim	3

No. 56 2 Speed Self Tailing Winch

Item No.	Part No.	Description	Quantity
1	B.0325	Pan Hd. Posidriv Screw M5 x 12mm Long	4
2A	5001099	Stripper Arm - Chrome	1
2B	5001095	Stripper Arm - Bronze	1
3	B.0339	Pan Hd. Posidriv Screw M6 x 40mm Long	3
4	5001097	Upper Crown	1
5	5001098	Stripper Ring	1
6	5001096	Lower Crown	1
7A	5001103	Drum - Alloy	1
7B	5001102	Drum - Chrome	1
7C	5001110	Drum - Bronze	1
8	5000645	Gear Spindle	2
9	5000017	Roller Bearing	5
10	5001107	Ratchet Gear	1
11	5000722	Pawl Spring	4
12	1264/8	Pawl	4
13	15001108	Pawl Gear	1
14	15000019	Roller Bearing	1
15	B.2092	Spirolox Internal Ring	1
16	15000646	Flanged Washer	2
17	15000648	Hollow Dowel	3
18	15001101	Base	1
19	B.0806	Skt. Hd. Cask Screw M10 x 25mm Long	3
20	15001105	Ratchet Gear	1
21	15001100	Centre Stem	1
22	15001106	Pawl Gear	1
23	15000644	Drum Washer	1
24	15044121	Roller Bearing	3
25	15001109	Spindle Assembly	1
26	15000387	Collet	2
27	15000379	Top Cap	1
28	15000655	Shim	3

No.55ST

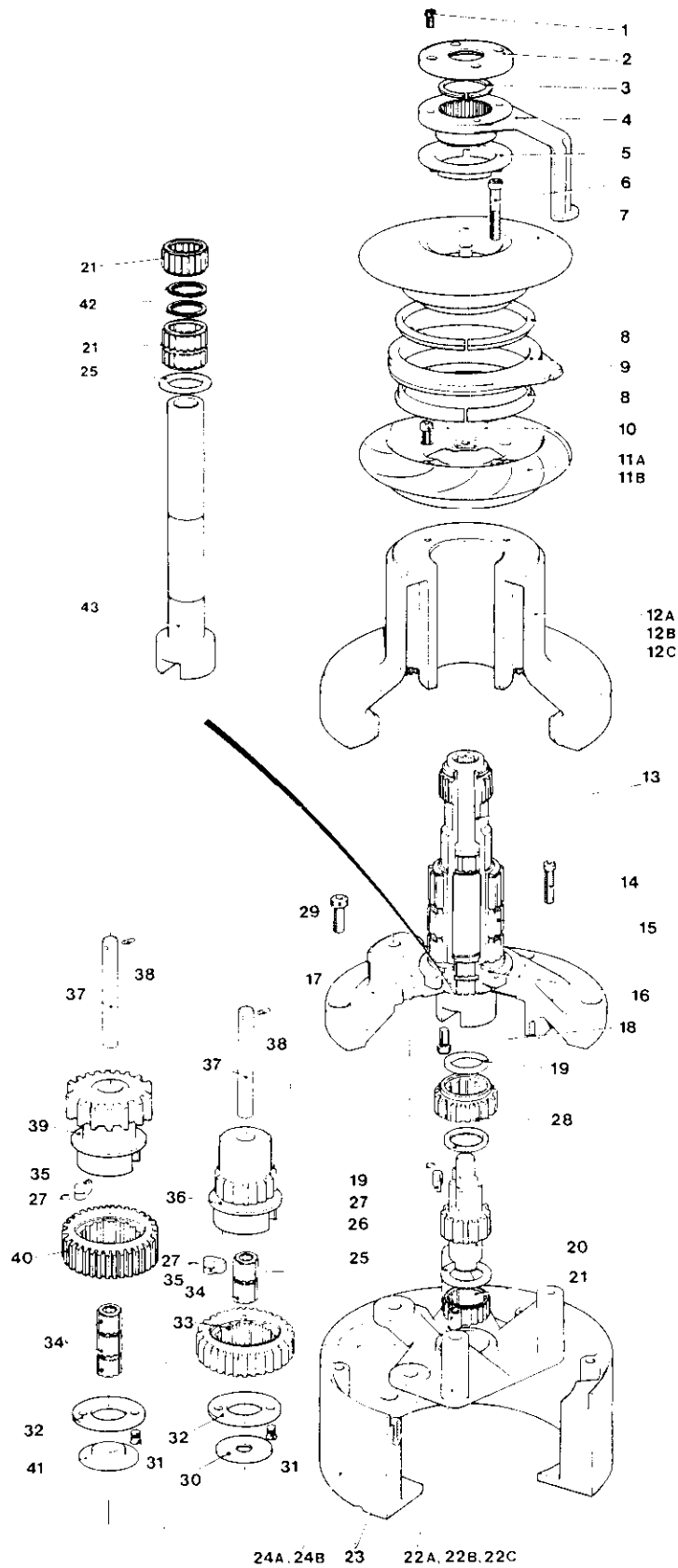

No. 55 2 Speed Self Tailing Winch

Item No.	Part No.	Description	No. Off
1	B 0733	Skt. Hd. Cap Screw – 1/4" UNC x 3/8" Long	4
2	15044639	Top Cap	1
3	15044637	Split Coilet	2
4	15055648	Stripper Arm	1
5	15044627	Flanged Bush	1
6	B 0731	Skt. Hd. Cap Screw— 1/4" UNC x 1 3/4" Long	3
7	15055644	Upper Crown Plate	1
8	15055641	Stripper Ring Insert	2
9	15055649	Stripper Ring	1
10	B0720	Skt. Hd. Cap Screw – 1/4" UNC x 3/4" Long	3
11A	15055645	Lower Crown Plate	1
11B	B 2405	Heli – Coil Insert	3
12A	15000277	Drum – Bronze	1
12B	15000278	Drum – Alloy	1
12C	15000279	Drum – S. Steel	1
13	15000191	Upper Centre Stem	1
14	B0698	Skt. Hd. Cap Screw – 5/8" UNC x 1 1/2" Long	3
15	15044121	Roller Bearing	3
16	15000287	Drum Washer	1
17	15000125	Lower Centre Stem	1
18	B0737	Skt. Hd. Cap Screw – 5/8" UNC x 1/2" Long	6
19	15000303	Spacer	2
20	15000234	Spindle – Extension	1
21	15000019	Roller Bearing	4
22A	15000252	Bridge Piece	1
22B	15000053	Sleeve – Bridge Piece	1
22C	B2401	Heli – Coil Insert	3
23	15065111	Hollow Dowel	2
24A	15000265	Base	1
24B	B2408	Heli-Coil Insert	4
25	15000024	Washer	2
26	1260/8	Pawl	2
27	1260/7	Pawl Spring	6
28	15000254	Ratchet Gear	1
29	B 0714	Skt. Hd. Cap Screw – 3/8" UNC x 3/4" Long	4
30	15000247	Washer	1
31	B0511	Csk. Screw – 2BA x 3/8" Long	4
32	1302/17	Retaining Plate	2
33	15000260	Ratchet Gear	1
34	15000017	Roller Bearing	5
35	1264/8	Pawl	4
36	15000342	Idler Gear	1
37	15000236	Gear Spindle	2
38	B 1501	Spirol Pin	2
39	15000262	Pawl Gear	1
40	15000261	Ratchet Gear	1
41	15000306	Flanged Washer	1
42	B 2086	Circlip	2
43	15000237	Main Spindle	1

No.65ST

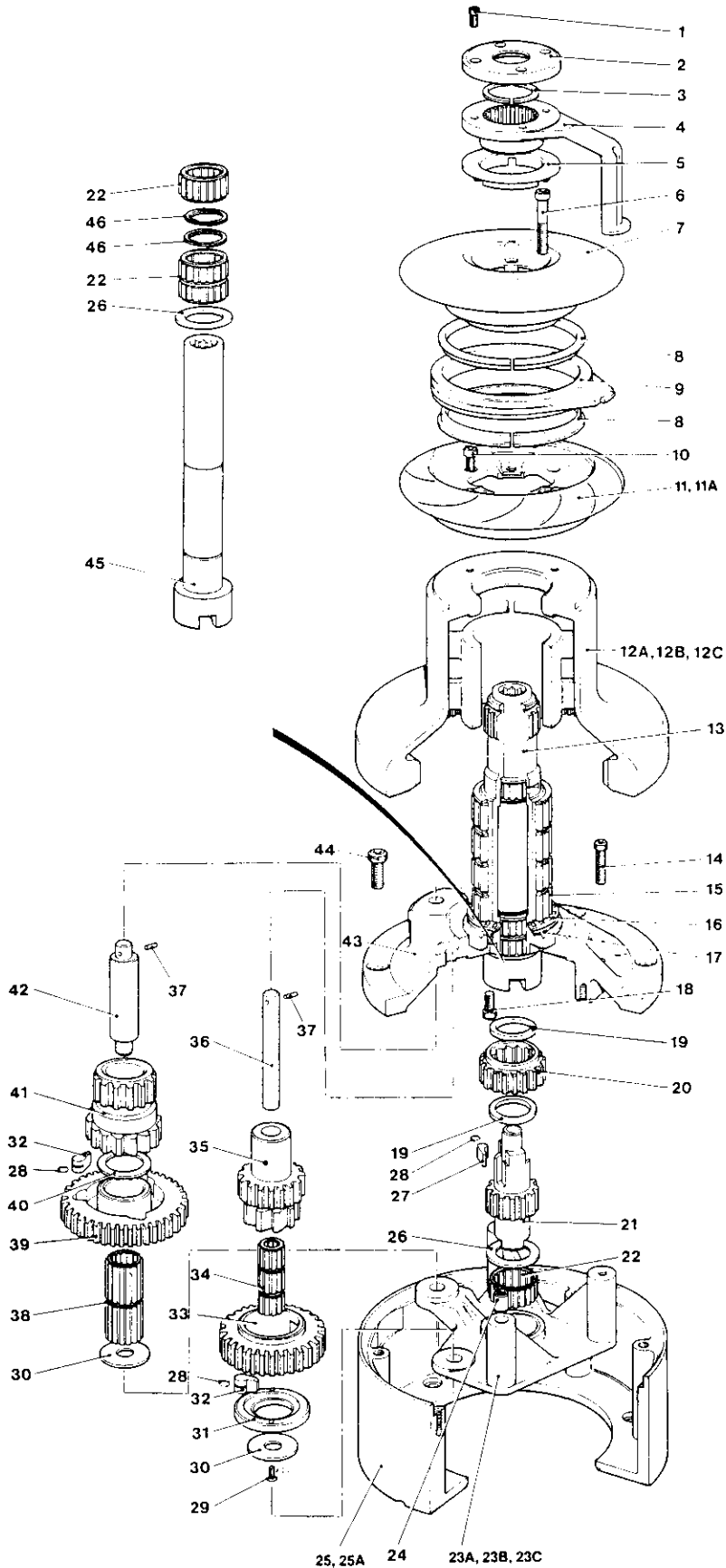

No. 65 2 Speed Self Tailing Winch

Item No.	Part No.	Description	No. Off
1	B 0733	Skt. Hd. Cap Screw -- 1/4" UNC x 3/8" Long	4
2	15044639	Top Cap	1
3	15044637	Split Collet	2
4	15065648	Stripper Arm	1
5	15044627	Flanged Bush	1
6	B 0731	Skt. Hd. Cap Screw -- 1/4" UNC x 1 3/4" Long	3
7	15065644	Upper Crown Plate	1
8	15065641	Stripper Ring Insert	2
9	15065649	Stripper Ring	1
10	B 0720	Skt. Hd. Cap Screw -- 1/4" UNC x 3/4" Long	3
11	15065645	Lower Crown Plate	1
11A	B 2405	Heli-Coil Insert	3
12A	15000032	Drum -- Bronze	1
12B	15000248	Drum -- Alloy	1
12C	15000081	Drum -- St. Steel	1
13	15000050	Centre Stem Upper	1
14	B 0698	Skt. Hd. Cap Screw -- 5/16" UNC x 1 1/2" Long	3
15	15044121	Roller Bearing	4
16	18080015	Thrust Bearing	1
17	15000082	Drum Washer	1
18	B 0730	Skt. Hd. Cap Screw -- 5/16" UNC x 5/8" Long	8
19	15000303	Spacer	2
20	15000242	Ratchet Gear	1
21	15000241	Spindle Extension	1
22	15000019	Roller Bearing	4
23A	15000048	Bridge Piece	1
23B	15000053	Sleeve -- Bridge Piece	1
23C	B 2401	Heli -- Coil Insert	3
24	15065111	Hollow Dowel	2
25	15000197	Base Alloy	1
25A	B 2408	Heli -- Coil Insert	6
26	15000024	Washer	2
27	1260/8	Pawl	2
28	1260/7	Pawl Spring	7
29	B 0511	Csk. Screw -- 2 BA x 3/8" Long	2
30	15000247	Washer	2
31	15000023	Retaining Plate	1
32	1264/8	Pawl	5
33	15000040	Pawl Gear	1
34	15000017	Roller Bearing	3
35	15000245	Idler Gear	1
36	15000240	Gear Spindle	1
37	B 1501	Spirol Pin	2
38	15000018	Roller Bearing	2
39	15000244	Pawl Gear	1
40	15000246	Washer	1
41	15000243	Ratchet Gear	1
42	15000239	Gear Spindle	1
43	15000049	Centre Stem Lower	1
44	B 0714	Skt. Hd. Cap Screw -- 3/8" UNC x 3/4" Long	6
45	15000238	Main Spindle	1
46	B 2086	Circlip	2

No.1

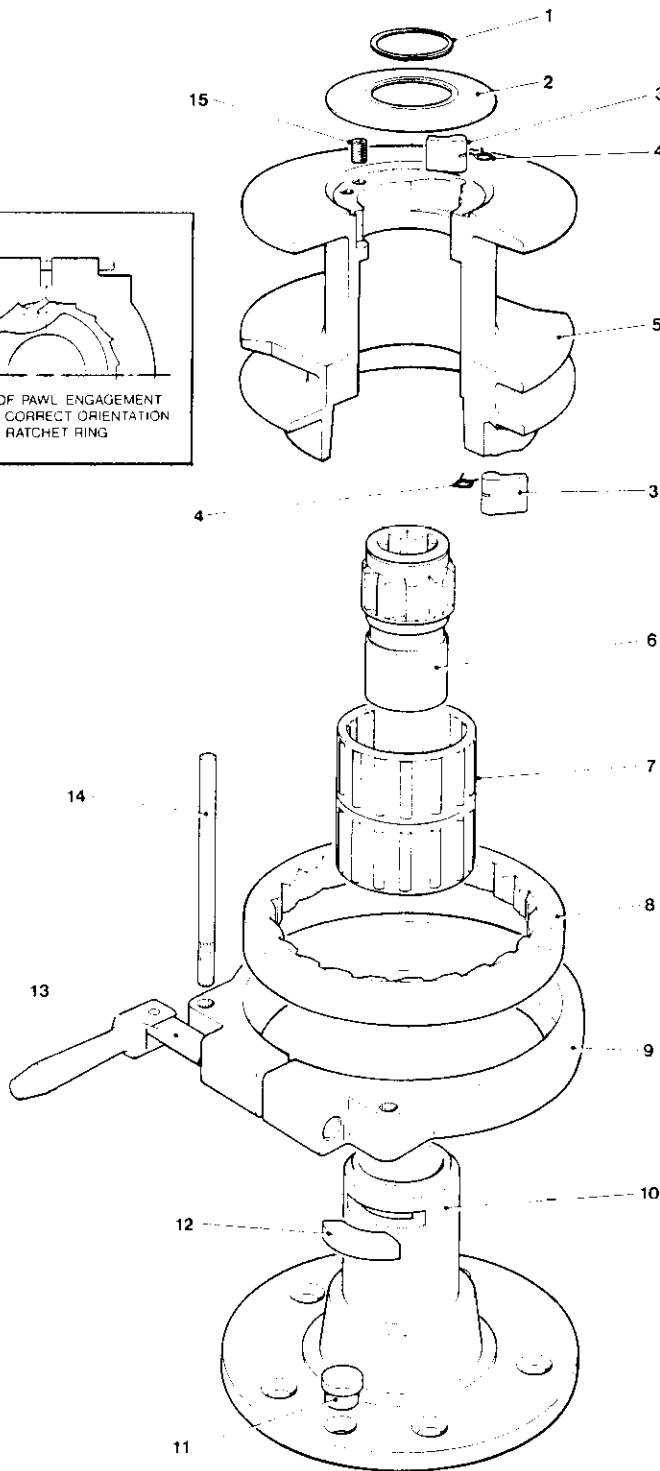
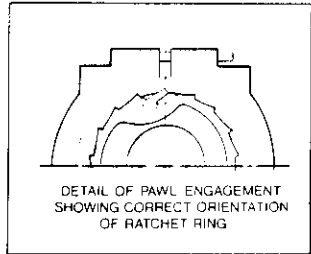

No. 1 Halliard Winch

Item No.	Part No.	Description	No. Off
1	B 2075	Circlip	1
2	18000047	Top Cap	1
3	1260/8	Pawl	4
4	1260/7	Pawl Spring	4
5	15001022	Drum	1
6	15008003	Spindle	1
7	15008007	Roller Bearing	2
8	15001024	Ratchet Ring	1
9	15001025	Brake Strap	1
	B 1992	Halliard Plate	1
10	15001021	Centre Stem	1
11	15001008	Locating Pin	1
12	15008005	Key	1
13	15001010	Brake Lever	1
	15001011	Brake Screw	1
	15001009	Handle Rivet	1
14	15001006	Guard Rod	2
15	B 0901	Grub Screw	2

COMMANDER FLUID POWER
PUSH BUTTON SAILING

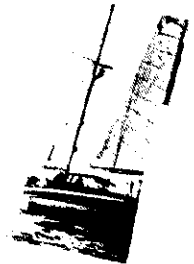

PORTLIGHTS



WINCHES

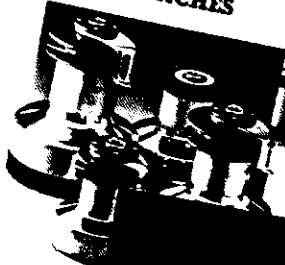

SLS
LEWMAR



System
LEWMAR

HIGH PERFORMANCE
HARDWARE

HIGH PERFORMANCE
SLEEVE PACKAGES

Specialty Ball Bearings
Custom Designed for Rig Use.

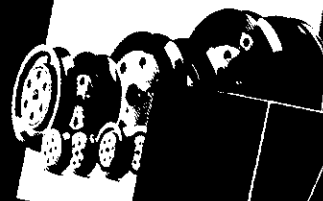

LEWMAR

ROD
RIGGING

ROLLSTOP
HATCH

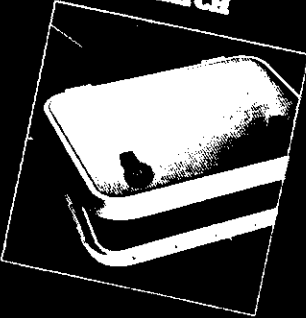

System
LEWMAR

- Winches
- Deck Hardware
- Rollstop Hatch
- Portlight
- Custom Deck Systems
- Navtec Rigging
- Navtec Hydraulics
- Commander Fluid Power
- Sailing Systems
- Servicing

For further information
contact your Lewmar
distributor



Lewmar Worldwide Service and Spares



Full service care, spare parts and assistance are available from Lewmar offices and distributors worldwide. In case of any difficulty with your Lewmar winches contact your nearest Lewmar office or distributor.

Lewmar Marine Limited (Head Office)
Southmoor Lane, Havant
Hampshire PO9 1JJ, England
tel: Havant (0705) 471841-3
tix: 86342 LEWMAR G
fax: (0705) 476043

Lewmar Marine Inc (West Coast)
927 Newhall Street, Costa Mesa,
California 92627 USA
tel: (714) 6317260
tix: 6836047 LMRWC
fax: 714 642 6474

Lewmar Sud Europe SARL
Avenue Louis Lumiere
ZI De Perigny
17000 La Rochelle, France
tel: 46 44 39 66
tix: 792202 YACHT E F
fax: 46 44 49 44

Lewmar Marin AB
Box 6073, S-172 06 Sundbyberg
Sweden
tel: (08) 98 04 75
tix: 15184 LEWMAR S

Lewmar Marine Inc (East Coast)
23 Broad Common Road, Bristol
Rhode Island 02809, USA
tel: (401) 253 6200
tix: 7103871 155 LEWMAR BROL
fax: (401) 253 9967

Lewmar Marine Limited
1410 Speers Road, No. 2 Oakville
Ontario, Canada L6L 5M1
tel: (416) 827 8910
tix: 906 3666 CNCP EDS TOR

Lewmar Mid-Europe B.V.
Branderweg 19
8042 PD Zwolle, Benelux
tel: (38) 214668
tix: 42298 LEWMA NL
fax: (38) 215642

Lewmar Guarantee

Lewmar winches have been developed over many years by extensive testing aboard the world's finest ocean racers, long distance cruising yachts and match racing yachts such as 12 metres. They are manufactured to quality standards in excess of those required by Lloyds and only the finest materials are used.

If installed, used and maintained as described in this leaflet, they will give outstanding performance.

Lewmar undertake that any winch which proves defective in materials or workmanship within 1 year of the date of supply will be repaired or replaced FREE OF CHARGE provided that the winch is returned by the registered owner to the nearest Lewmar office or distributor for examination. Lewmar reserve all rights on determining the nature of the alleged fault and their decision is final.

All rights reserved
Copyright Lewmar Marine Ltd 1987
Printed in England
Produced by Commercial Print Services

Code No. SM5a